

Stationary Photoionization Detector SPID3

User Manual



from firmware revision : 1.07.032

ACI Analytical Control Instruments GmbH
Volmerstraße 9A
D-12489 Berlin
Germany

© ACI Analytical Control Instruments GmbH. All rights reserved.

EU-Konformitätserklärung / EU-Declaration of conformity

Der Hersteller oder sein in der Gemeinschaft niedergelassener Bevollmächtigter:
The manufacturer or the European Authorized Representative:

ACI Analytical Control Instruments GmbH
Volmerstraße 9A
D-12489 Berlin
Germany

erklärt hiermit, dass das Produkt / declares that the product:

Stationary Photoionization Detector SPID3-*

Artikelnummer / Part No.: 0003239, 0003317, 0003327,
0003323, 0003324, 0003326

basierend auf der EG-Baumusterprüfbescheinigung / based on the EC-Type Examination Certificate:

FTZÚ 15 ATEX 0110X
IECEx FTZÚ 15.0030X



II 2G Ex db IIC T6 Gb IP64 -40 °C ≤ T_a ≤ +60 °C

Die Ausstellung des Qualitätssicherungsnachweises gemäß Anhang IV der ATEX-Richtlinie 2014/34/EU erfolgt durch FTZÚ in Ostrava-Radvanice, Zertifizierungsstellennummer: 1026.

Quality assurance notification complying with Annex IV of the ATEX-Directive 2014/34/EU has been issued by FTZÚ notified body number: 1026.

FTZÚ 15 ATEX Q 003, IECEx QAR 15.0002/00, EN ISO/IEC 80079-34:2018

Normen / Harmonized standards: EN IEC 60079-0:2018, EN 60079-1:2014, EN 50271:2018

Dieses Produkt erfüllt die Bestimmungen der Richtlinie 2014/30/EG (elektromagnetische Verträglichkeit):
This product is in conformance with the EMC-Directive 2014/30/EU (electromagnetic compatibility):

Normen / Harmonized standards: EN 50270:2015, EN 50270:2015/AC:2016

RoHS-Richtlinie 2011/65/EU & 2015/863 - Beschränkung gefährlicher Stoffe in elektrischen und elektronischen Geräten.
RoHS-Directive 2011/65/EU & 2015/863 - restriction of hazardous substances in electrical and electronic equipment.

ACI Analytical Control Instruments GmbH
Dipl.-Ing. Andreas Otto
Managing Director

Berlin, 25.02.2025

1 Contents

1	Contents.....	4
2	General.....	7
3	Safety and Usage Instructions.....	7
3.1	Terms and Symbols.....	7
3.2	Correct Use.....	8
3.3	Liability Information.....	8
3.4	Safety and Precautionary Measures to be adopted.....	8
3.5	Permanent Instrument Warranty.....	9
4	SPID3 at a Glance.....	10
5	Installation.....	11
5.1	Mechanical Installation.....	11
5.2	Electrical Installation.....	12
5.2.1	How To – Install Electrical Connection.....	12
5.3	Filter Port – Installation.....	14
5.3.1	Filter Port – Filter Cartridge.....	14
5.3.2	How To – Install the Filter Port – Filter Cartridge.....	15
5.4	Sample Port – Installation.....	15
5.4.1	How To – Install the Sample Port – Dust Filter.....	15
6	User Interface.....	16
6.1	Startup.....	16
6.2	Display Overview.....	16
6.3	Operating Buttons.....	17
6.3.1	How To – Activate a Button.....	17
6.4	Instrument Info.....	17
6.4.1	How To – Activate the Instrument Info.....	17
6.5	Instrument Menu.....	18
6.5.1	How To – Activate the Instrument Menu.....	18
6.5.2	How To – Change Password.....	18
7	Operation.....	20
7.1	Calibration.....	20
7.1.1	General.....	20
7.1.2	Preparations before Calibration / Calibration Test.....	20
7.2	Calibration Procedure.....	21
7.2.1	Calibration Methods.....	21
7.2.2	Calibration zero gas from sample input.....	21
7.2.3	Calibration zero gas from filter input.....	21

7.2.4	How To – Start Calibration	21
7.2.5	Calibration sequence for standard and extended calibration	22
7.2.6	Calibration Verification.....	23
7.2.7	How To – Start Calibration Test	23
7.3	Measurement configuration	24
7.3.1	How To – Configure measurement	24
7.3.2	Calibration Data	25
7.3.3	How To – Select Calibration Data	25
7.3.4	Response Factor.....	26
7.3.5	List of Response Factors for PID with 10.6 eV Lamp:	26
7.3.6	How To – Select Response Factor from list.....	26
7.3.7	How To – Select Response Factor manually	27
7.3.8	Response Screen.....	27
7.3.9	Alarm Setting.....	27
7.3.10	How To – Configure Alarm Setting	27
7.4	Purge Mode.....	28
7.4.1	Purge Time	28
7.4.2	Measurement Time	28
7.4.3	Smart purging.....	31
7.4.4	How To – Setup Automatic Purge and smart purging	33
7.4.5	How To – Setup Manual Purge	34
7.5	Interfaces.....	35
7.5.1	MODBUS (RS485)	35
7.5.2	How To – Configure RS485 (MODBUS).....	35
7.5.3	MODBUS Register Map	36
7.5.4	Current Loop (4 ... 20 mA, 0 ... 5 mA or 0 ... 10 mA).....	38
7.5.5	How To – Configure Current Loop.....	39
7.5.6	How To – use HART BUS	39
7.6	Service.....	40
7.6.1	Reset (Default Setting).....	40
7.6.2	How To – Reset to factory defaults	41
7.6.3	How To – Change display contrast	41
7.6.4	Diagnostic.....	42
7.6.5	How To – Activate Diagnostic	42
7.7	Measurement Ranges	43
7.8	Resolution of Measurement Result	43
7.9	Relays	44
7.10	Output States	45

8	Maintenance and Service	46
8.1	Maintenance Intervals	46
8.2	Safety Screws	47
8.3	How To – Open the Device	48
8.4	How To – Remove the PCU-PCB.....	49
8.5	How To – Replace the PID Lamp.....	50
8.6	How To – Clean the PID Lamp.....	51
8.6.1	Cleaning procedure:	52
8.6.2	Hose routing inside the unit:.....	52
8.7	How To – Replace the Filter Port – Filter Cartridge	53
8.8	How To – Replace the Sample Port – Dust Filter.....	54
8.9	Configuraron jumper and service communication	55
8.10	Default configuration jumper attachment.....	56
8.11	How To – Connect to configure and update device with service communication.....	56
9	Technical Data	57
10	Approvals.....	59
10.1	Marking, Certificates and Approvals According to the Directive 2014/34/EU (ATEX).....	59
10.1.1	Special Conditions for Safe Use	60
10.1.2	EMC Conformance according to the Directive 2014/30/EU.....	60
10.2	Marking and Certificates according to IECEx.....	61
10.2.1	Special Conditions for Safe Use	62
10.2.2	EMC Conformance according to the Directive 2014/30/EU.....	62
11	Appendix.....	63
11.1	Error Messages.....	63
11.2	Mechanical Drawing.....	64
12	Contact Information	65
13	Ordering Information	66
14	Scope of Delivery.....	67
15	Spare Parts	68
16	Accessories.....	71

2 General

The company ACI Analytical Control Instruments (hereinafter the ‘manufacturer’) provides with the Stationary Photoionization Detector SPID3 (hereinafter the ‘device’) a continuously measuring detector for volatile organic compounds (VOCs) with a high stable hollow cathode lamp with Ceramic Discharge Channel with an ionization potential < 10.6 eV. The use of new technologies for the excitation source and the sensor allows a high stability of measurement and longer maintenance intervals. An integrated active carbon filter and the sampling circuit allow automatic purging and automatic calibration.

3 Safety and Usage Instructions

3.1 Terms and Symbols

In this manual, certain common terms and symbols used to warn you of dangers or to give you cautions that are important in avoiding injury or damage. Observe and follow these cautions and regulations to avoid accidents and damage. These terms and symbols explained below.



DANGER

Indicates a hazardous situation, which, if not avoided, **WILL** result in death or serious injury.



WARNING

Indicates a hazardous situation, which, if not avoided, **COULD** result in death or serious injury.



CAUTION

Indicates a hazardous situation, which, if not avoided, **MAY** in minor or moderate injury.



NOTICE

Indicates a property damage message.



Usage

Indicates a helpful information, hint or recommendation.

3.2 Correct Use

The device is suitable for outdoor and indoor applications without limitations, e.g. offshore industry, chemical and petrochemical industry, water and sewage industry. The device comes in a flameproof enclosure and is useable in explosive atmosphere.

It is imperative that this user manual be read and observed when using the product. In particular, the safety instructions, as well as the information for the use and operation of the product, must be carefully read and observed. Furthermore, the national regulations applicable in the user's country must be taken into account for a safe use.



WARNING

This product is supporting life and health. Inappropriate use, maintenance or servicing may affect the function of the device and thereby seriously compromise the user's life. Before use, the product operability must be verified. The product must not be used if the function test is unsuccessful, it is damaged, a competent servicing/maintenance has not been made, genuine manufacturer spare parts have not been used.

Alternative use, or use outside this specification will be considered as non-compliance. This also applies especially to unauthorised alterations to the product and to commissioning work that has not been carried out by manufacturer or authorised persons.

3.3 Liability Information

The manufacturer accepts no liability in cases where the product has been used inappropriately or not as intended. The selection and use of the product are the exclusive responsibility of the individual operator. Product liability claims, warranties also as guarantees made by manufacturer with respect to the product are voided, if it is not used, serviced or maintained in accordance with the instructions in this manual.

3.4 Safety and Precautionary Measures to be adopted



WARNING

The following safety instructions must be observed implicitly. Only in this way the safety and health of the individual operators and the correct functioning of the instrument can be guaranteed.

- The device described in this manual must be installed, operated and maintained in strict accordance with their labels, cautions, instructions, and within the limitations stated.
- The device is designed to detect volatile organic compounds or vapours in air.
- Do not mount the device in direct sunlight as this could cause overheating of the sensor.
- The device must be installed vertical with the filter port unit downward to avoid plugging of the gas inlets by particles or liquids.
- The only absolute method to ensure proper overall operation of the device is to check it with a known concentration of the gas for which it has been calibrated. Consequently, calibration checks must be included as part of the routine inspection of the system.
- As with all devices of these types, high levels of, or long exposure to, certain compounds in the tested atmosphere could contaminate the sensor. In atmospheres where the device may be exposed to such materials, calibration must be performed frequently to ensure that the operation is dependable and display indications are accurate.
- Use only genuine manufacturer replacement parts when performing any maintenance procedures provided in this manual. Failure to do so may seriously impair instrument performance. Repair or

alteration of the device, beyond the scope of these maintenance instructions or by anyone other than an authorised manufacturer service personnel, could cause the product to fail to perform as designed.

- The device is designed for applications in hazardous areas under atmospheric conditions.
- Significant dust deposits on the gas inlets will increase the response time of the device. Checks for dust deposits must be done at regular intervals.

3.5 Permanent Instrument Warranty

Warranty

Seller warrants that this product is designed and manufactured to the latest internationally recognized standards by manufacturer under a quality management system that is certified to ISO 9001. As such the manufacturer warrants that this product will be free from defective parts and workmanship and will repair or (at its option) replace any instruments which are or may become defective under proper use within twenty four [24] months from date of commissioning by an approved manufacturer representative.

This warranty does not cover wearing parts, i.e. parts inside the gas way like valves, pumps, lamp and other or damage caused by accident, abuse or abnormal operating conditions.

Defective goods must be returned to manufacturer premises accompanied by a detailed description of any issue. Where return of goods is not practicable manufacturer reserves the right to charge for any site attendance where any fault is not found with the equipment. Manufacturer shall not be liable for any loss or damage whatsoever or howsoever occasioned which may be a direct or indirect result of the use or operation of the contract goods by the buyer or any party.

This warranty covers instrument and parts sold to the buyer only by authorized distributors, dealers and representatives as appointed by manufacturer. The warranties set out in this clause are not pro rata, i.e. the initial warranty period is not extended by virtue of any works carried out there under.

In no event will manufacturer be liable for any incidental damages, consequential damages, special damages, punitive damages, statutory damages, indirect damages, loss of profits, loss of revenues, or loss of use, even if informed of the possibility of such damages. Manufacturers liability for any claims arising out of or related to this product will in no case exceed the order value. To the extent permitted by applicable law, these limitations and exclusions will apply regardless of whether liability arises from breach of contract, warranty, tort (including but not limited to negligence), by operation of law, or otherwise.

4 SPID3 at a Glance

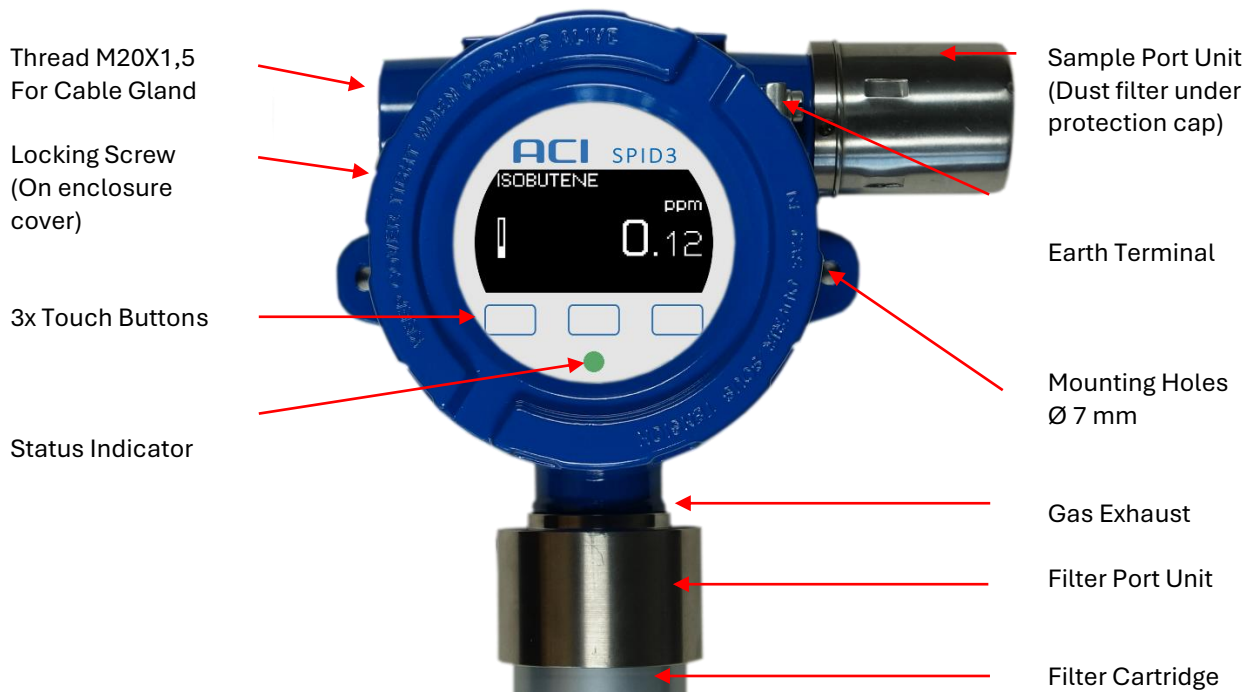

5 Installation



WARNING

The device contains sensitive electronic components. Disconnect the power supply before maintenance and service.

The device should be installed where gas leaks are expected. The installation position depends on the gas density, either in the upper area of the room under the ceiling for gases lighter than air or close to the ground for gases heavier than air. Also, consider how air movement may affect the ability of the device to detect gas. The display on the front of the instrument must always be clearly visible; the view must not be obstructed.



Before beginning the installation, check that the delivered components are complete and correct referring to the shipping documents and the sticker on the shipment carton.



When preparing the assembly, make sure that the mounting arrangement is correct for the particular device.

5.1 Mechanical Installation

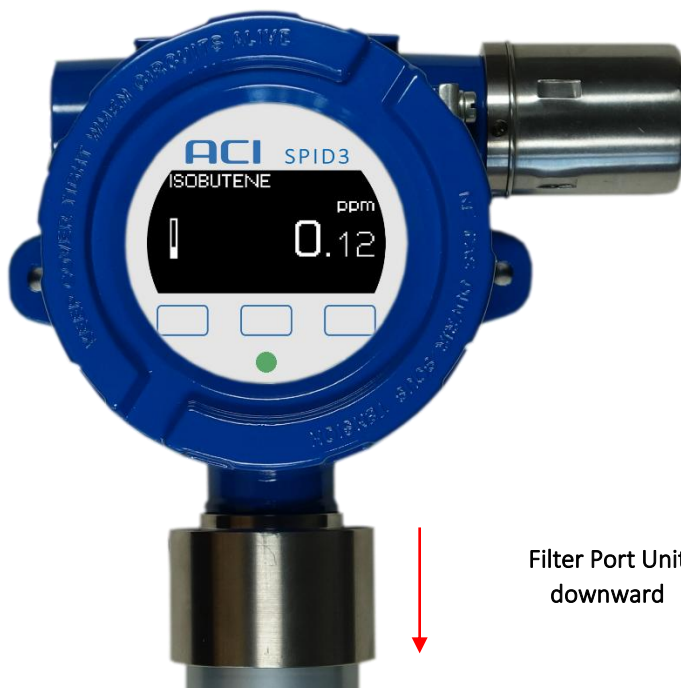

How To – Attaching to the Wall

1. Using the device fixing holes (Ø 7 mm) as a template, mark the holes for the two fixing screws.
2. Drill two holes of appropriate diameter.
3. Attach the device to the wall, vertical with the filter port unit downward, using 6 mm diameter screws with an appropriated length, at the place of installation.



The device must be installed vertical with the filter port unit downward to avoid plugging of the gas inlets by particles or liquids.

5.2 Electrical Installation



WARNING

The device must be installed only in compliance with the applicable regulations, otherwise the safe operation of the instrument is not guaranteed.

- Shielded cable for measuring devices is recommended.
- All cable shields to be terminated to ground earth at one end only.
- Do not connect to DC power supply network. Recommended, separate power supply.
- ATEX and/or IECEx cable glands Ex d IIC certified must be mandatory installed.
- Water or impurities can penetrate the instrument through the cable. In hazardous areas, it is recommended to install the cable in a loop just before entry into the instrument or to slightly bend it to prevent water from entering.



NOTICE

The power supply is defined as 24 VDC.

5.2.1 How To – Install Electrical Connection

1. Open the device. (See chapter How To – Open the Device)
2. Unscrew clamping nut at the cable gland.
3. Put clamping nut on the cable.
4. Insert cable for connection into the device.
5. Connect the cables to the respective contacts of the plugs to the unit connections.
6. Tighten cable gland clamping nut, check that cable cannot move within the cable gland.
7. Reinsert PCU unit. Reinsert MCU unit. Make sure that the connecting columns are plugged in correctly.
8. Close enclosure lid and secure the locking screw.

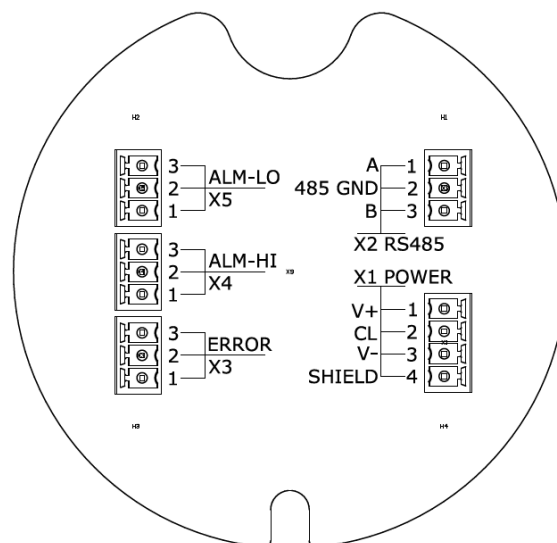

X1 Power

- | | | | |
|---|--------|-------------|-------------------------|
| 1 | V+ | 24 VDC | [Positive Supply] |
| 2 | CL | 4 ... 20 mA | [Current Loop Output] |
| 3 | V- | 0 VDC | [Negative Supply] |
| 4 | SHIELD | | [Ground Earth] |

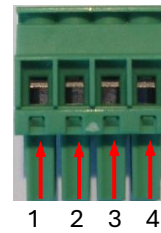

X2 RS485 (MODBUS)

- | | | |
|---|-----|----------------------------|
| 1 | A | [Non Inverting Terminal] |
| 2 | GND | [Isolated Ground] |
| 3 | B | [Inverting Terminal] |

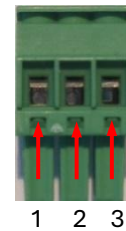

X3 ERROR

- | | | |
|---|-----------|--|
| 1 | Relay NC | [Normally Closed De-Energized Contact] |
| 2 | Relay COM | [Common Contact] |
| 3 | Relay NO | [Normally Open De-Energized Contact] |



X4 ALARM HIGH

- | | | |
|---|-----------|--|
| 1 | Relay NC | [Normally Closed De-Energized Contact] |
| 2 | Relay COM | [Common Contact] |
| 3 | Relay NO | [Normally Open De-Energized Contact] |

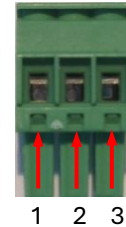

X5 ALARM LOW

- | | | |
|---|-----------|--|
| 1 | Relay NC | [Normally Closed De-Energized Contact] |
| 2 | Relay COM | [Common Contact] |
| 3 | Relay NO | [Normally Open De-Energized Contact] |



The terminal plugs accept AWG 26 (0.14 mm²) to AWG 16 (1.5 mm²) wire.
Do not assemble at temperatures below 0°C.

5.3 Filter Port – Installation



CAUTION

Do not use the device without filter cartridge, dust filter and protection cap. Impurities within ambient air can get into gas path and destroy the sensor.

5.3.1 Filter Port – Filter Cartridge

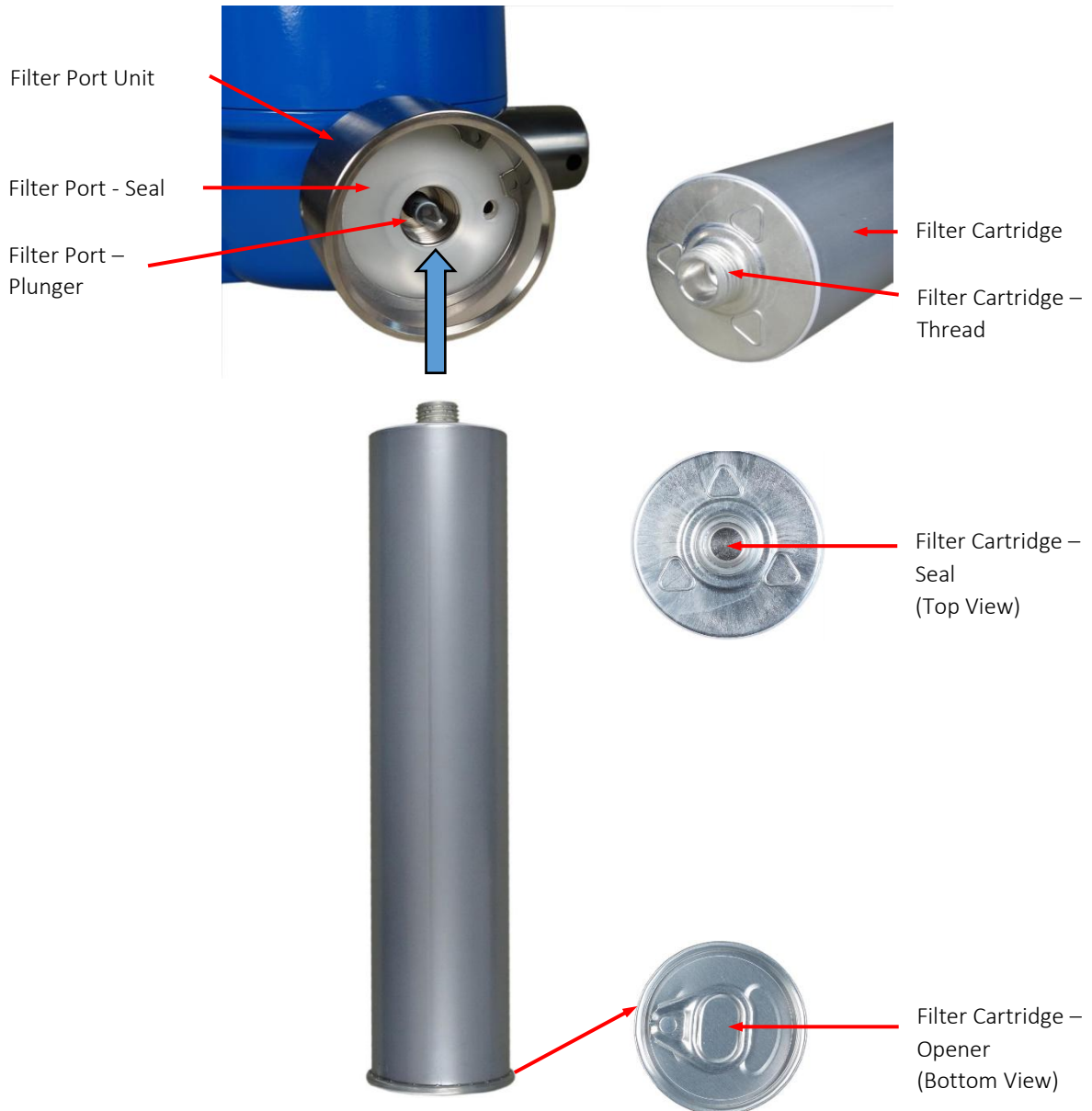

5.3.2 How To – Install the Filter Port – Filter Cartridge

1. Check that the filter port – seal is fitted and not damaged.
2. Check that the filter cartridge – seal is not broken.
3. Open the filter cartridge before installation by using the opener (ring pull).
4. Screw the filter cartridge into the filter port unit. Only light force is required.



Calibrate the device after installation of a new filter cartridge.

5.4 Sample Port – Installation



CAUTION

Do not use the device without filter cartridge, dust filter and protection cap. Impurities within ambient air can get into gas path and destroy the sensor.

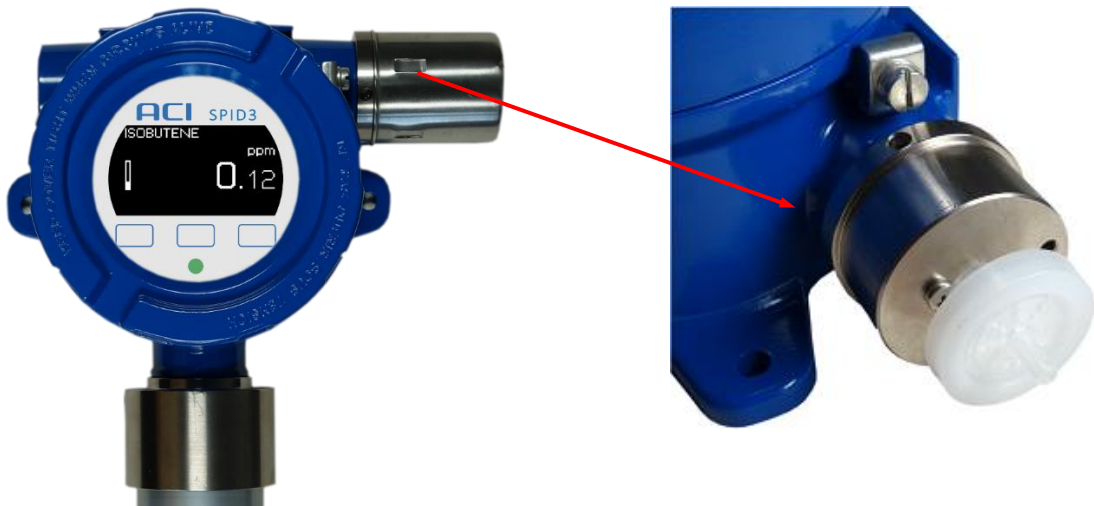

5.4.1 How To – Install the Sample Port – Dust Filter

1. Remove the sample port – protection cap by pulling sideward.
2. Unscrew the old sample port – dust filter
3. Screw in the new sample port – dust filter (free of impurities)
4. Check that the sample port – dust filter is correct assembled.
5. Replace sample port – protection cap with gas intake hole downward.



Calibrate the device after installation of a new dust filter.

6 User Interface

6.1 Startup

After the power supply voltage has been applied, the device is automatically switched on and after approximately 10 seconds the display and status indicator switch on. The device carries out a warmup and self-diagnostic sequence, which takes approximately 60 seconds. During this period, the current loop output is set to startup state (see chapter 7.10 Output States).

If the self-diagnostic sequence is satisfactorily completed, the main screen is displayed, and the current loop output moves to a value representing the measurement value.

6.2 Display Overview

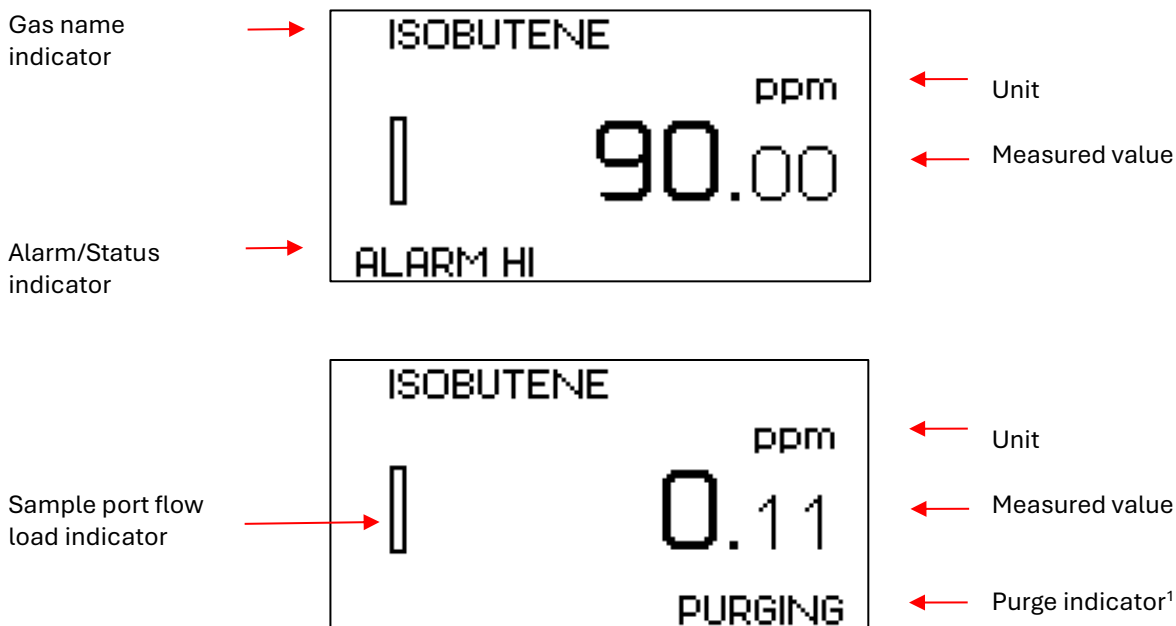

Sample Port - Dust Filter should be replaced when sample port flow load indicator is filled up completely.

¹ available if Auto Purge is activated

6.3 Operating Buttons

The device is operated using three touch sensitive fields, marked with borderlines below the display (touch operation with gloves may not be possible).

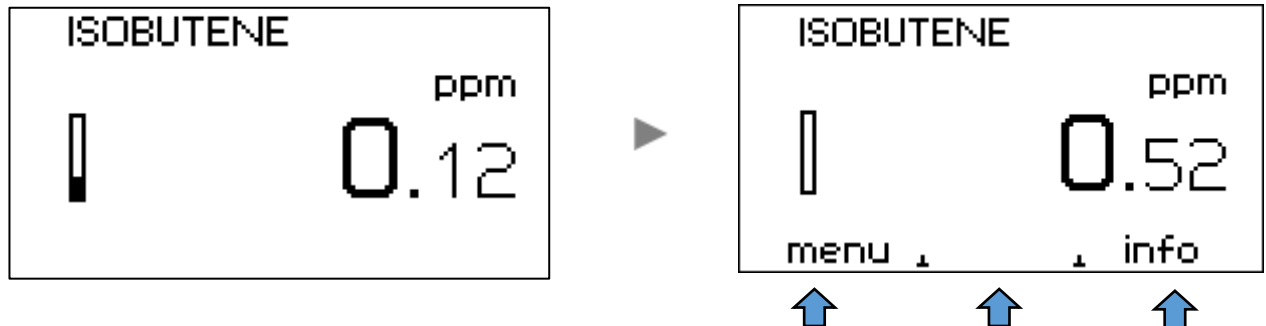

6.3.1 How To – Activate a Button

1. Touch the marked areas directly below the display on the corresponding area.
2. The display will response to user input and shows the navigation bar.
3. Select the desired menu item.



After a period of 5 seconds of inactivity, the navigation bar disappears automatically.

6.4 Instrument Info



This feature allows inspecting the instruments settings **WITHOUT** leaving the measurement function.

6.4.1 How To – Activate the Instrument Info

1. Select the item “info” at the navigation bar.
2. Select the item “next” repeatedly to scroll through the info screens.
3. Select the item “back” to go to measurement view.

After a period of 120 seconds the instrument info goes automaticly back to measurment.

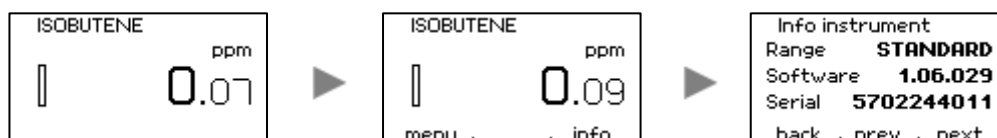

6.5 Instrument Menu



The instrument menu is protected by a four-digit password and should only be changed by qualified and authorized persons. **The default password consist of last four digits of device serial number.**



WARNING

When entering the instrument menu the measurement function will ABORT. No measurement will be performed, all alarms will be switched off, the current loop, the relays and the LEDs will be set to maintenance state (see chapter Output States). Therefore, access to menu is protected by password and you will be prompted twice before entering the menu. **The password can be changed manually or via PC remote connection.**

6.5.1 How To – Activate the Instrument Menu

1. Select the item “menu” at the navigation bar
2. Confirm to exit measurement to access the instrument main menu
3. Enter the required password and confirm the process with “next”
4. Instruments main menu is entered

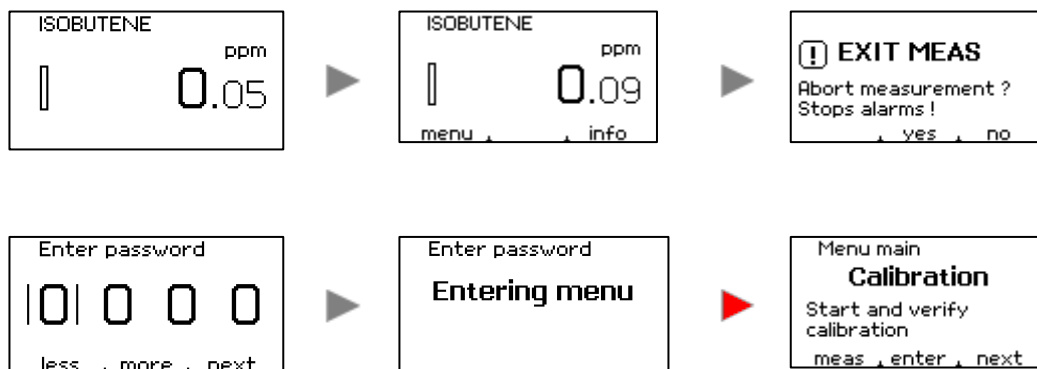

6.5.2 How To – Change Password

1. Select the item “menu” at the navigation bar
2. Confirm to exit measurement to access the instrument main menu
3. Enter the required password (refer 6.5) and confirm the process with “next”
4. Instruments main menu is entered
5. Step with “next” through menu options still option “Service” then select “enter”
6. Step with “next” through menu options still option “Password” then select “enter”
7. Modify password digits to new password with “less” or “more” and “next”
8. Set Password with “accept”
9. Repeat sequence to confirm new password
10. **Note new password on a safe place**

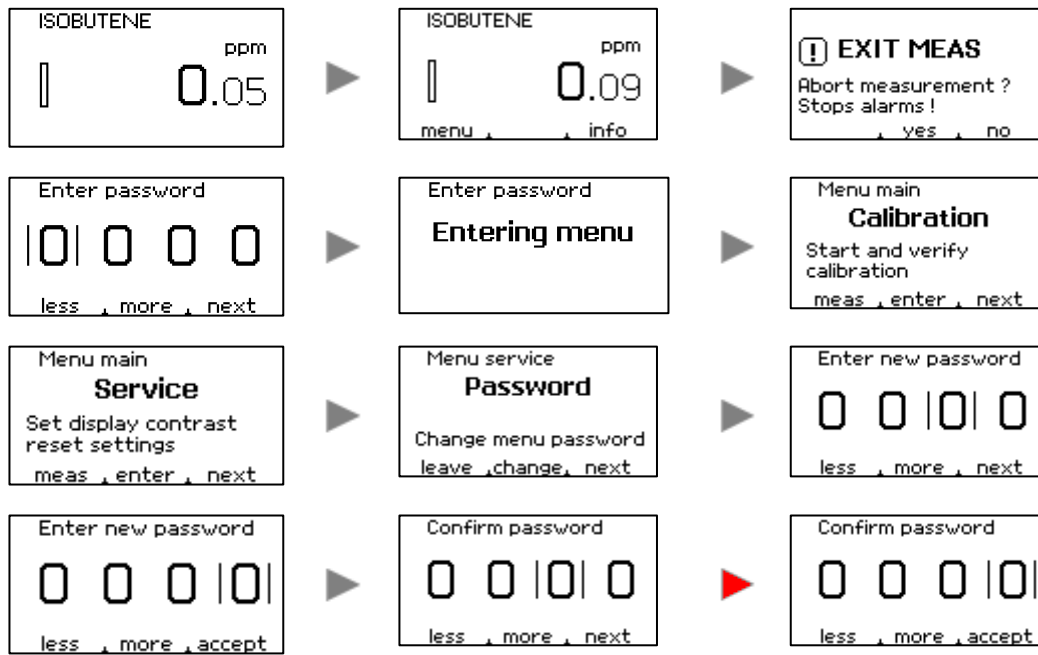

7 Operation

7.1 Calibration



WARNING

Test gases used for calibration can be a health risk. Proper ventilation or extraction must be ensured.

7.1.1 General

The calibration must be done at regular intervals in accordance with applicable national and regional regulations. The device calibration and the accuracy of the measuring can easily be checked at any time by using the build-in **Calibration Test** function. The device must be calibrated after installation.



Connect power supply to the device at least one hour before attempting a calibration.

7.1.2 Preparations before Calibration / Calibration Test

To perform a calibration, you need a pressure cylinder of SPAN Gas and / or ZERO Gas, a flow reducer, a tube and a T-piece. The flow reducer should provide a flow of at least 500 ml/min. The T-piece should be installed between flow reducer and sample port – dust filter. The open tube length on T-piece junction should be 300 – 500 mm. (see following connection scheme)



For calibration, it is recommended to use the **Calibration Kit** from accessories. (see chapter Accessories)

7.2 Calibration Procedure

7.2.1 Calibration Methods

The device supports two different methods for calibration. (**Standard Calibration** with span gas [Isobutene in air] and **Extended Calibration** with span gas [User gas in air] with known concentration). Which calibration method is carried out, depends on the measurement task, e.g. overview measurements, workplace monitoring, control measurements, worst-case measurements, environmental measurements and emission measurements.



Both calibration data for **Extended Calibration** and **Standard Calibration** are stored independently of one another. Via the Instrument Menu >> MEAS CONFIG, the user can choose most appropriate calibration data setting for his measurement application.

Both calibration methods using a two-point-calibration, with zero gas from filter or sample input.

7.2.2 Calibration zero gas from sample input

- Both, fresh air (zero gas) and calibration gas (span gas) must be applied successively to the Sample Port – Gas Input.
- The user will be asked for applying the right gas during the calibration sequence.

7.2.3 Calibration zero gas from filter input

- Only calibration gas (span gas) must be applied to the Sample Port – Gas Input.
- Fresh air (zero gas) will be taken automatically from the Filter Port – Cartridge.
- The user will be asked for applying the span gas during the calibration sequence.



After starting any calibration, calibration gas [zero or span gas] must be applied until calibration step is finished. The calibration procedure can be cancelled at any time by pressing “abort”. The previous device calibration will be used.

7.2.4 How To – Start Calibration

1. Go to the instrument menu and select “Calibration”
2. Select “enter” to go to calibration screen
3. Press “run” to start new calibration and follow the instructions on the screen

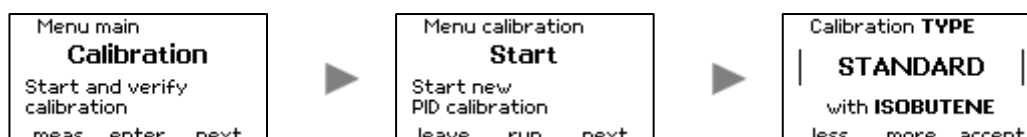

7.2.5 Calibration sequence for standard and extended calibration

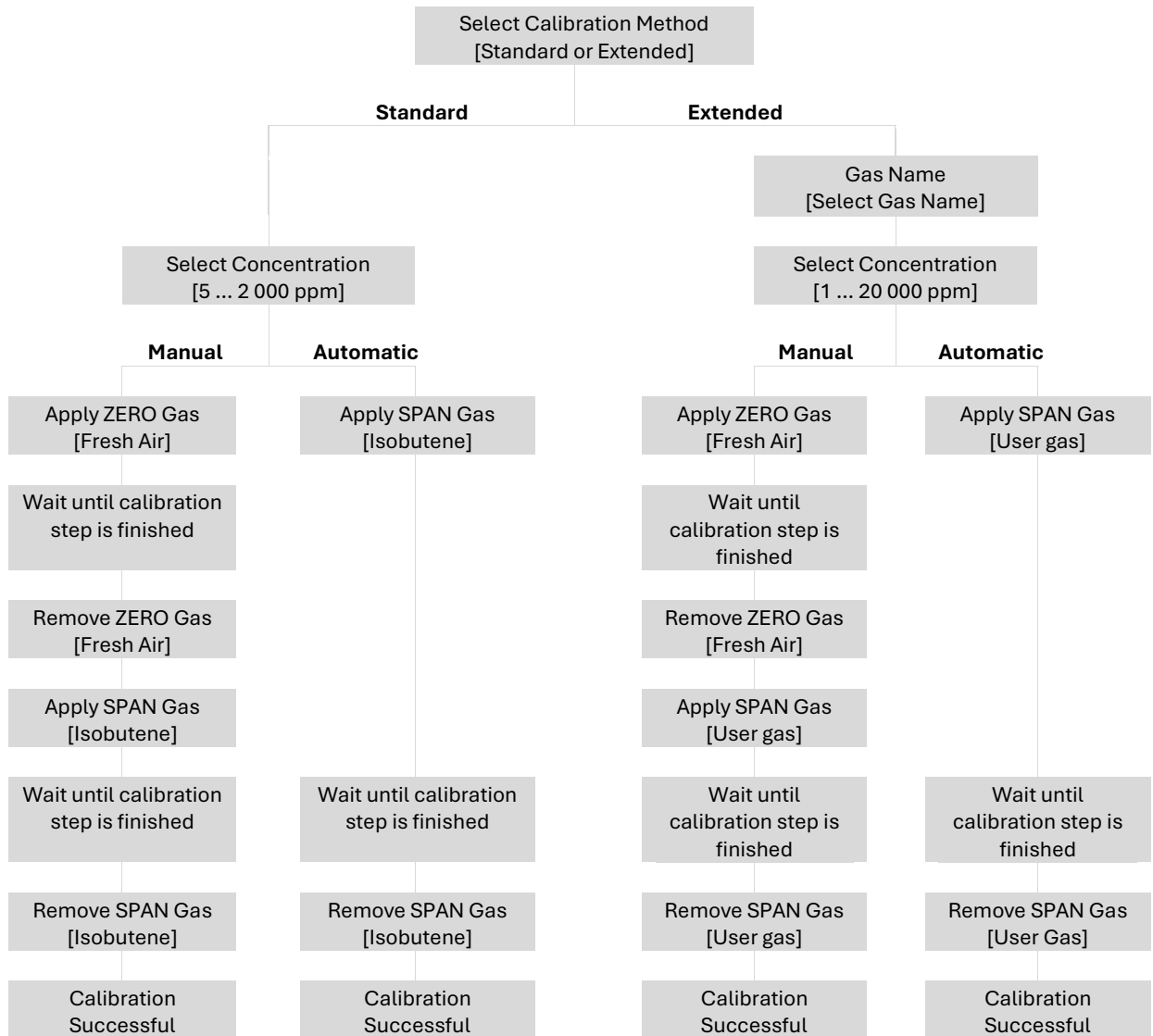

7.2.6 Calibration Verification

The calibration test verifies the PID sensor calibration.

7.2.7 How To – Start Calibration Test

1. Go to the Instrument Menu and select “Calibration”
2. Select “enter” to go to calibration screen
3. Select with “next” “Verify”
4. Press “run” to test the calibration

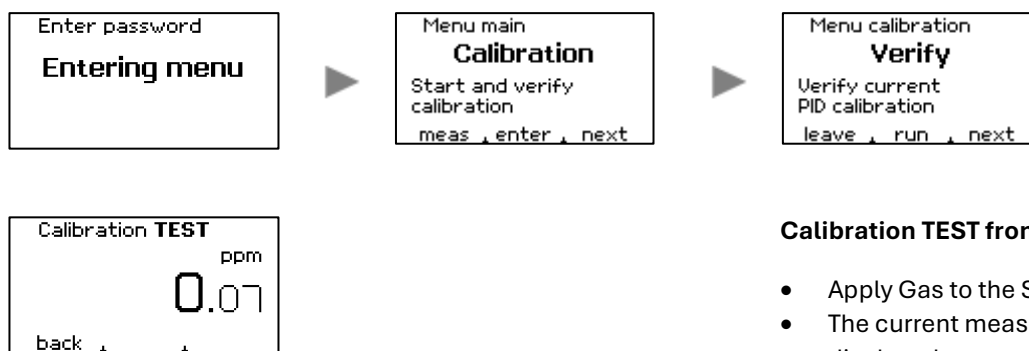

7.3 Measurement configuration

This menu will be used for device settings.

7.3.1 How To – Configure measurement

1. Go to the Instrument Menu and select “Meas config”.
2. Select “select” to start measurement configuration

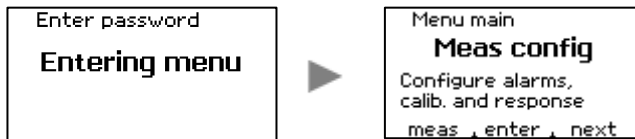

Calibration	<p>This menu item allows you to select which calibration data will be used for the measurement.</p> <p>The user can select between the following two calibration data settings:</p> <ul style="list-style-type: none"> • STANDARD or EXTENDED 	See section: Calibration Data
Response	<p>This menu item allows you to select a response factor.</p> <ul style="list-style-type: none"> • ISOBUTENE, BENZENE, CS2, Custom, ... 	See section: Response Factor
Alarms	<p>This menu item allows you to select two user configurable alarm levels.</p> <ul style="list-style-type: none"> • ALARM LO and ALARM HI 	See section: Alarm Setting

7.3.2 Calibration Data

The device supports two different methods for calibration. (**Standard Calibration** with SPAN Gas [Isobutene in air] and **Extended Calibration** with SPAN Gas [User gas in air] with known concentration)

This menu setting allows you to select which type of calibration data are used for measurement.



Both calibration data for **Extended Calibration** and **Standard Calibration** are stored independently of one another.

7.3.3 How To – Select Calibration Data

1. Go to the Instrument Menu and select “Meas config”
2. Select “enter” to start measurement configuration
3. Select “Calibration”, “select” calibration data setting and “accept”

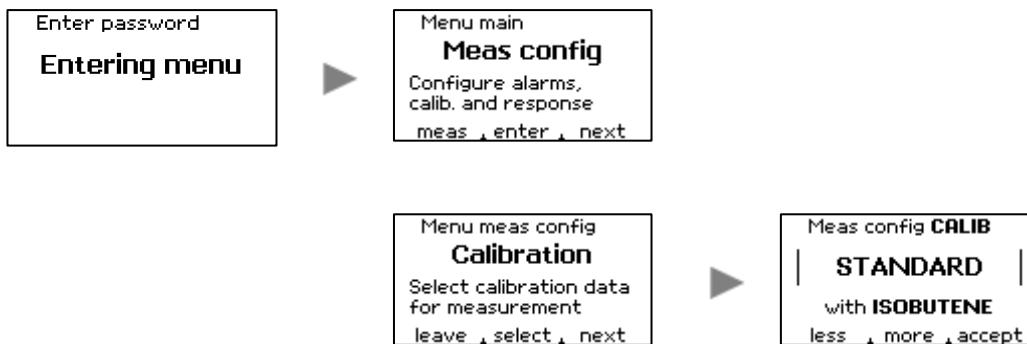

7.3.4 Response Factor

Based on SPAN Gas [Isobutene] calibration for correct reading of other VOCs it is necessary to set a response factor. This factor reflects the sensitivity of the known VOC compared with the calibration gas and can be more or less than 1. A list of predefined response factors based on official literature and custom factors are stored in the device and can be selected by user. Additionally, the user got the possibility to specify a list of up to 100 particular response factors by an additional configuration software via PC (optional communication cable required). After selecting a response factor, the gas name will be shown on the display. As a second option, a response factor can be set manually. In this case, the display will show the response factor value instead of the gas name.

7.3.5 List of Response Factors for PID with 10.6 eV Lamp:

List Item	Gas Name	Response Factor
1.	ISOBUTENE	1.00
2.	BENZENE	0.55
3.	CS2	1.20
4.	Custom 0.50	0.50
5.	Custom 1.25	1.25
6.	Custom 2.00	2.00
7.	Custom 5.00	5.00
8.		



The list of response factors is only available if **Standard Calibration** is selected.

7.3.6 How To – Select Response Factor from list

1. Go to the Instrument menu and select “Meas config”
2. Select “enter” to start measurement configuration
3. Select “Response” and “Response list” to modify response setting

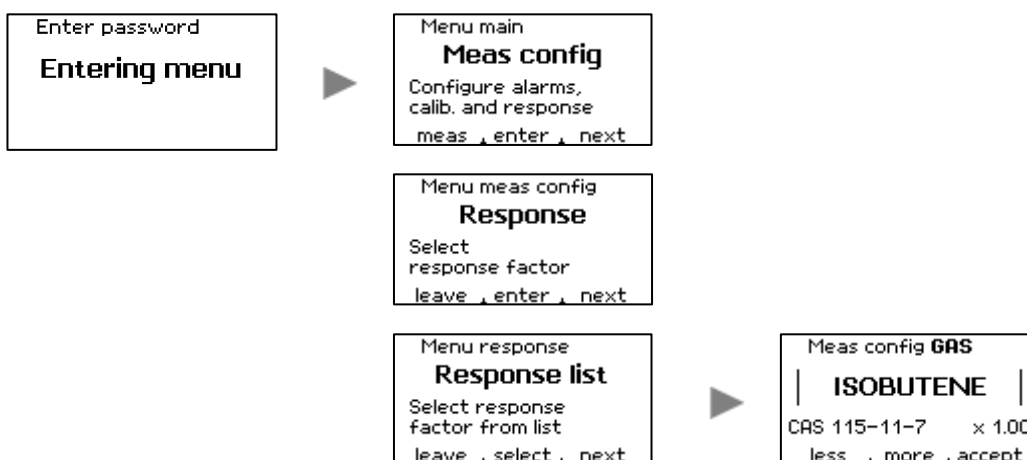

7.3.7 How To – Select Response Factor manually

1. Go to the Instrument menu and select “Meas config”
2. Select “enter” to start measurement configuration
3. Select “Response” “Response factor” to set factor manually (0.01 ... 100.00)

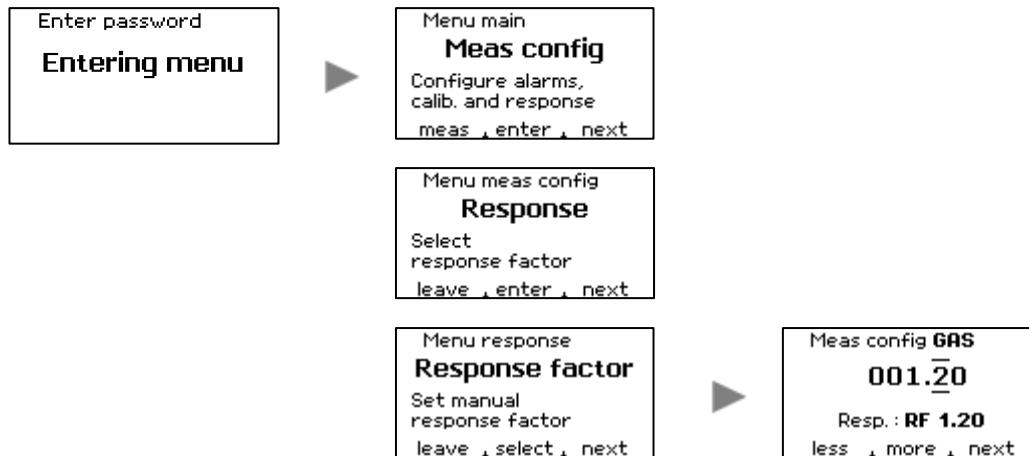

7.3.8 Response Screen

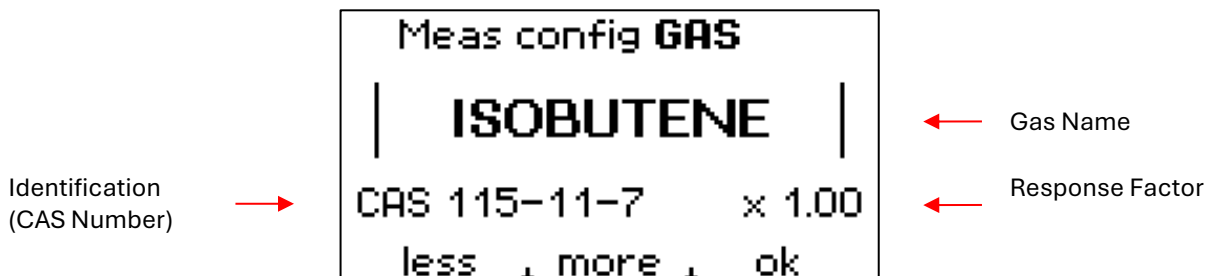

7.3.9 Alarm Setting



It is obligated to set “ALARM HI” higher than “ALARM LO”.

The device features two user configurable alarm levels:

ALARM LO	0.1 – 100 000 ppm
ALARM HI	0.2 – 100 000 ppm

7.3.10 How To – Configure Alarm Setting

1. Go to the Instrument Menu and select “Meas config”
2. Select “enter” to start measurement configuration
3. Select Alarm LO level and change parameter
4. Select Alarm HI level and change parameter

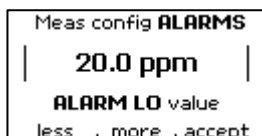
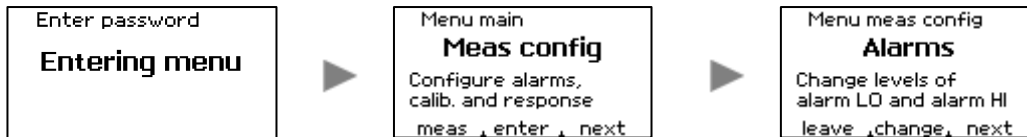

ALARM LO level

- 0.1 – 100 000 ppm

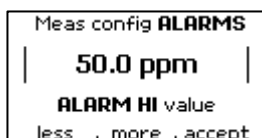

ALARM HI level

- 0.2 – 100 000 ppm

7.4 Purge Mode

Under most environmental conditions, a pollution of the PID sensor can decrease the measurement performance. Parts that are exposed to the sample gas like tubes, pump, valve, PID sensor and lamp window surface can be polluted on its surface. This may lead to incorrect measuring values over time. To provide the possibility of working under such hard conditions a purge mode is installed. The principle of this mode is a periodic interchange between ambient air, which is filtered by the active carbon filter and sample gas. The switching can be performed automatically by self-chosen time intervals or by one time manual user input.

The **Automatic Purge** mode is the default-operating mode for long-term measurements. Therefore, two time intervals must be configured.

7.4.1 Purge Time

This parameter determines the duration of the purge cycle, during which the device draws ambient air filtered by an active carbon filter. During this time, the last valid measurement value is retained on the display. The purge time also includes a fixed recovery period of 10 seconds at the end of each cycle.

The purge time should **not be set too** long if the measured value is subject to frequent and rapid changes. Longer times are possible, for example, when monitoring the service life of filters.

7.4.2 Measurement Time

This parameter defines the duration of the measurement cycle, during which the device draws sample gas from the sample port. During this time, the measurement value is continuously updated and displayed.

If real-time monitoring of measured values is not required and regular updating is sufficient, the time for the measuring cycle can be set to a short time.

Auto purge timing

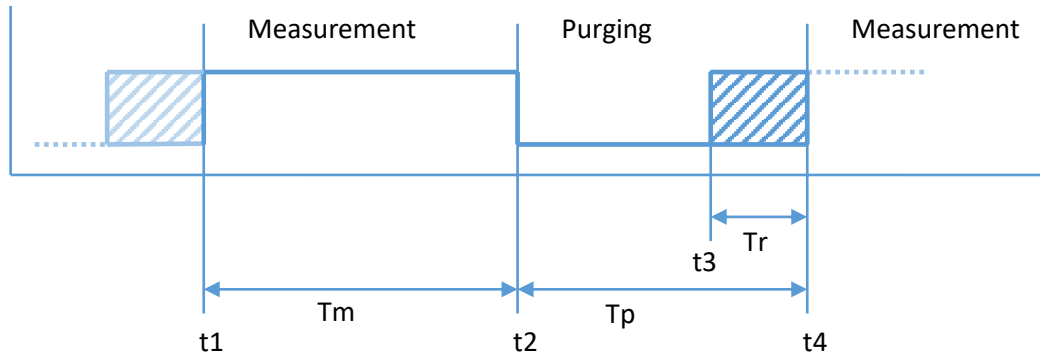

- Tm MEAS TIME
- Tp PURGE TIME (including recovery time (Tr))
- Tr Recovery time (fixed to 10 seconds)

t1	Begin of measurement cycle. The currently final measurement result is show at display.
t2	Begin of purge cycle. The valve is switched to filter input. The display shows the last measurement result at moment t2.
t3	Begin of recovery cycle. The valve is switched to sample input. The display still shows the last measurement result from moment t2.
t4	Begin of next measurement cycle. The currently final measurement result is show at display.

7.4.3 Smart purging

In addition to the positive effects, purging has the disadvantage that no changes to the measurement signal can be detected during this time.

Smart purging operates like automatic purging, with one key difference: it delays the purging process if the measurement signal is rapidly changing.

Smart purging ensures that the purge cycle is intelligently delayed when rapid changes in the measurement signal are detected, allowing the system to capture and display accurate data without interruption.

The smartpurge limit is the change of measurement value to start a delay of purging. It is the percentage value of the current measurement value to the value 10 seconds ago.

For a measurement value of 10 ppm and a smart purge limit of 10 % a measurement value change of 1 ppm or more (10 ppm to 11 ppm or 10 ppm to 9 ppm) will delay the purging cycle.

If the measurement signals are generally close to zero, it is advisable to set a higher percentage value (20%-50%). If there are usually significant measurement signals, a lower value (e.g. 3%-15%) should be set depending on the typical fluctuation of the measured values so that the desired flushing cycle is activated regularly.

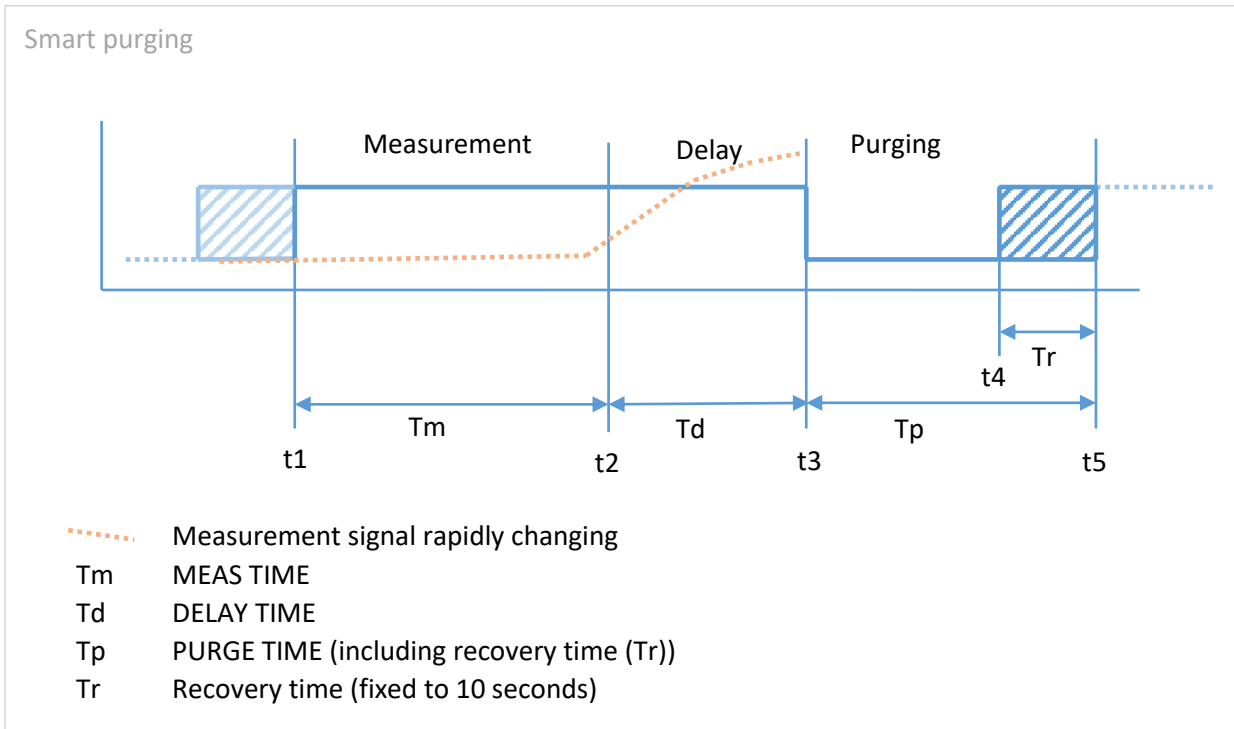

t1	<p>Begin of measurement cycle. The final measurement result from previous cycle is show at display.</p>
t2	<p>The smart delay cycle of the measurement begins. The currently measurement result is displayed until rapidly changing values stabilises and the change falls below the specified percentage of the measured value within the last 10 seconds.</p>
t3	<p>Begin of purge cycle when change of measurement value is below the adjusted smart purge limit. The valve is switched to filter input. The display shows the last measurement result at the moment t3.</p>
t4	<p>Begin of recovery cycle. The valve is switched to sample input. The display still shows the last measurement result from the moment t3.</p>
t5	<p>Begin of next measurement cycle. The currently measurement result is show at display until freezing at end of measuring cycle.</p>

7.4.4 How To – Setup Automatic Purge and smart purging

1. Go to the Instrument Menu and select “Purge”
2. Select “enter” to start configuration
3. Configure **Automatic Purge** settings by MEAS TIME and PURGE TIME

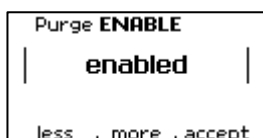
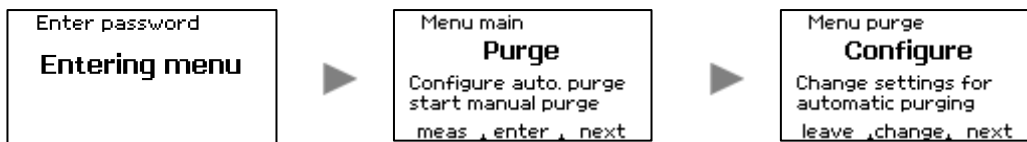

Activate Purge

Enable purge for further settings or disable it



Select MEAS TIME

Adjustable between 10 seconds and 4 weeks

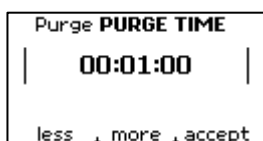

Select PURGE TIME

Adjustable between disabled, 30 seconds and 1 hour

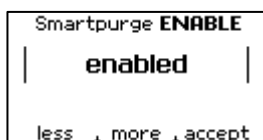

Enable Smart purging

Enable smart purging or disable it

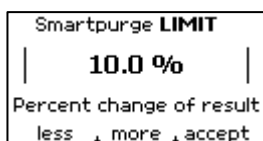

Select Smart purging level

Adjustable between 0.1 percent and 10000.0 percent



The **Purge** mode is made by default but can be **switched off**.

7.4.5 How To – Setup Manual Purge

1. Go to the Instrument Menu and select “Purge”
2. Select “enter” to start configuration
3. Select “Manual”
4. Select “PURGE TIME” and press “accept” to start purging
5. After Manual Purge the device changed to Start screen

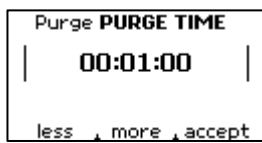
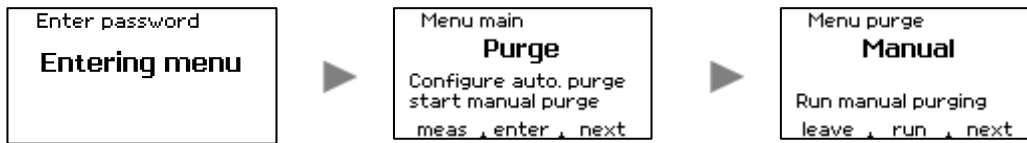

Select PURGE TIME

Adjustable between 1 minute and 1 hour

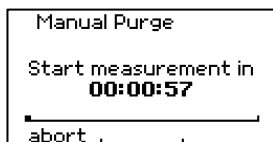

After purging the device independently returns again to the normal operation.



The **Manual Purge** mode can be selected at any time while the device is running.

7.5 Interfaces

7.5.1 MODBUS (RS485)

The device provides a RS485 (MODBUS) interface. This bus makes it possible to connect up to 32 devices including the host system to one line. For proper operation of the bus system, the first and the last device in chain must be terminated. The MODBUS protocol implementation provides ASCII and RTU modus and can be configured in the instrument menu.

7.5.2 How To – Configure RS485 (MODBUS)

1. Go to the Instrument Menu, enter “Interfaces” and “Modbus”
2. Select “change” to configure Modbus interface

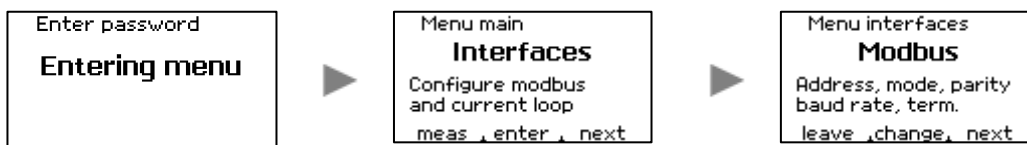

Modbus **ADDRESS**
| 010 |
ID must be unique in line
less , more , accept

Select SLAVE ID

- IDs from 1 to 247 are possible

Modbus **BAUD RATE**
| 115200 bd |
Same as master
less , more , accept

Select BAUDRATE

- 9600; 19200; 38400; 57600; 115200

Modbus **MODE**
| RTU |
Same as master
less , more , accept

Select MODE

- Select ASCII or RTU Mode

Modbus **PARITY**
| EVEN |
Same as master
less , more , accept

Select Parity

- Select Even, Odd or None

Modbus **TERM.**
| enable |
Termination resistor
less , more , accept

Select TERMINATION

- Select build in line termination resistor (120 Ohm)

Default Settings: (Reset (Default Setting))

7.5.3 MODBUS Register Map

Register 3xxx – Access via function code 0x04 (read only)

Instrument Identification

Register no	Format	Access	Length	Description
30001	String	Ro	32 byte	Device identification
30017	String	Ro	32 byte	Device name
30033	String	Ro	32 byte	Device serial number

Measurement Results

Register no	Format	Access	Length	Description
30100	Float	Ro	4 byte	Measurement result [ppm]
30102	Float	Ro	4 byte	Temperature [°C]
30104	Float	Ro	4 byte	Humidity [%rH]
30106	UInt32	Ro	4 byte	Status information ²
30108	Float	Ro	4 byte	Response factor
30110	Float	Ro	4 byte	Alarm LO level [ppm]
30112	Float	Ro	4 byte	Alarm HI level [ppm]
30114	Float	Ro	4 byte	Alarm over range level [ppm]
30116	Float	Ro	4 byte	Flow load [%]
30118	Float	Ro	4 byte	Not used, always 0.0

² see Status Information Bit Definition

Error codes

Up to 4 occurred errors can be identified by reading the error codes.

Register no	Format	Access	Length	Description
30120	UInt16	Ro	2 byte	Error 0 code (0, if not occurred)
30121	UInt16	Ro	2 byte	Error 1 code (0, if not occurred)
30122	UInt16	Ro	2 byte	Error 2 code (0, if not occurred)
30123	UInt16	Ro	2 byte	Error 3 code (0, if not occurred)

An error code interpreted as hexadecimal value is the code shown on display or described in appendix error messages.

Status Information Bit Definition

Bit	Description	Bit	Description
D00	1 = Alarm LO detected	D16	reserved (0)
D01	1 = Alarm HI detected	D17	reserved (0)
D02	reserved (0)	D18	reserved (0)
D03	1 = Over range detected	D19	reserved (0)
D04	1 = Under range detected	D20	reserved (0)
D05	1 = Filter dirty detected	D21	reserved (0)
D06	reserved (0)	D22	reserved (0)
D07	reserved (0)	D23	reserved (0)
D08	1 = Device is in initialization mode	D24	reserved (0)
D09	1 = Device is in measure mode	D25	reserved (0)
D10	1 = Device is in maintenance mode	D26	reserved (0)
D11	1 = Device is in idle mode	D27	reserved (0)
D12	1 = Extended calibration in use	D28	reserved (0)
D13	1 = Device is in purging	D29	reserved (0)
D14	reserved (0)	D30	reserved (0)
D15	reserved (0)	D31	1 = Device is in error mode

7.5.4 Current Loop (4 ... 20 mA, 0 ... 5 mA or 0 ... 10 mA)

The device is equipped with an analog current loop output, which converts the physical measurement result into an electrical signal. The device provides a 3-wire current loop output, which operates over the entire supply voltage range. The most common resistor in a 4 ... 20 mA loop is 250 ohm; however, depending on applied supply voltage the maximum load resistance must be considered.

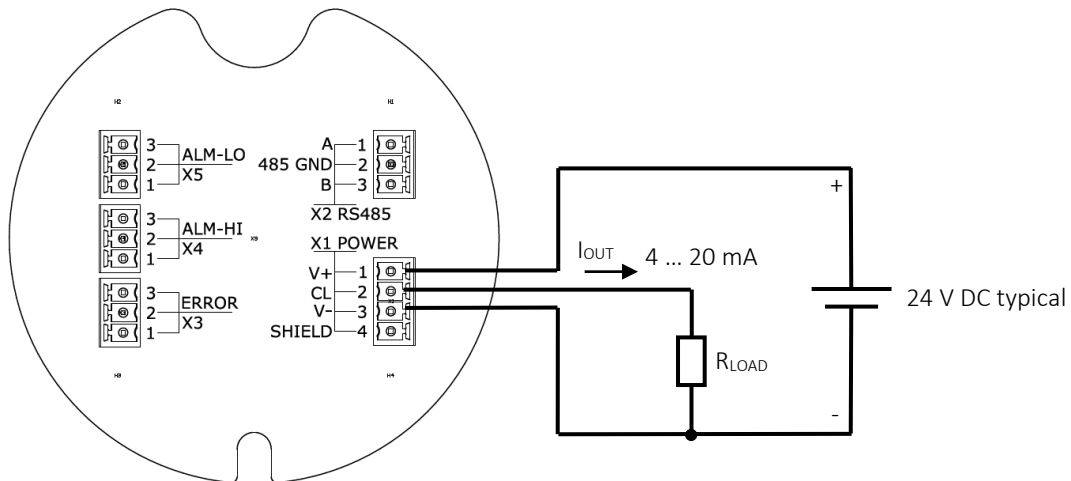

Supply Voltage	Maximum Load Resistance (R_{LOAD})
+10 V DC	330 Ohm
+12 V DC	450 Ohm
+24 V DC	900 Ohm

The output current (4 ... 20 mA, 0 ... 5 mA or 0 ... 10 mA) and the corresponding signal range (0 ... 20 000 ppm) can be selected.

	Example 1	Example 2	Example 3
Measurement result	80 ppm	80 ppm	12 ppm
Output range	4 ... 20 mA	4 ... 20 mA	0 ... 5 mA
Signal range	0 ... 100 ppm	0 ... 1000 ppm	0 ... 50 ppm
Output current	16.8 mA	5.28 mA	1.2 mA

7.5.5 How To – Configure Current Loop

1. Go to the Instrument Menu, enter “Interfaces” and “Current loop”
2. Select “change” to configure interface

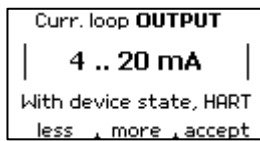
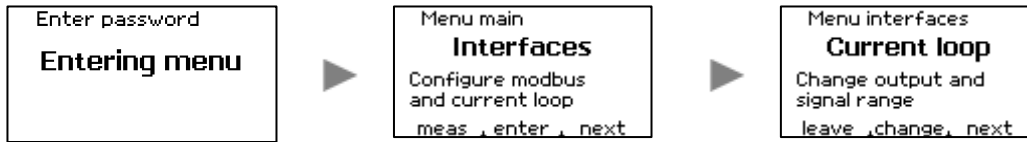

Select Current Loop OUTPUT

- 4 ... 20 mA (HART if available)
- 0 ... 5 mA (no HART)
- 0 ... 10 mA (no HART)

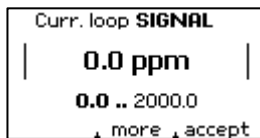

Select Current Loop SIGNAL

- Lower limit

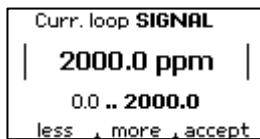

Select Current Loop SIGNAL

- Upper limit

7.5.6 How To – use HART BUS

For device variant with HART the current loop output must be set to 4 .. 20 mA to use the HART interface.

For device-specific HART implementation and information see document :

SPID3 – HART specification

7.6 Service

7.6.1 Reset (Default Setting)



You have to calibrate the instrument after executing this function.

The device can be restored to the original factory defaults.

Alarm levels	ALARM LO	20 % of measurement range
	ALARM HI	50 % of measurement range
Calibration		Standard Calibration
Current Loop	Output	4 ... 20mA
	Signal	0 ... 20 ppm (Low range) 0 ... 2000 ppm (Standard range) 0 ... 5 000 ppm (High range)
Modbus	Slave ID	10
	Mode	RTU
	Baud rate	115200
	Parity	even
	Termination	Enable
AutoPurge	Enable	true
	Meas Time	1 min
	Purge Time	1 min
	Smart enable	false
	Smart limit	10 %
Password	Set to default	last for digits of device serial number
Response Factor	ISOBUTENE	x 1.00

7.6.2 How To – Reset to factory defaults

1. Go to the Instrument Menu, enter “Service” and “Reset”.
2. Select “run” to reset the configuration to factory defaults.
3. Press “run” to confirm to reset device settings

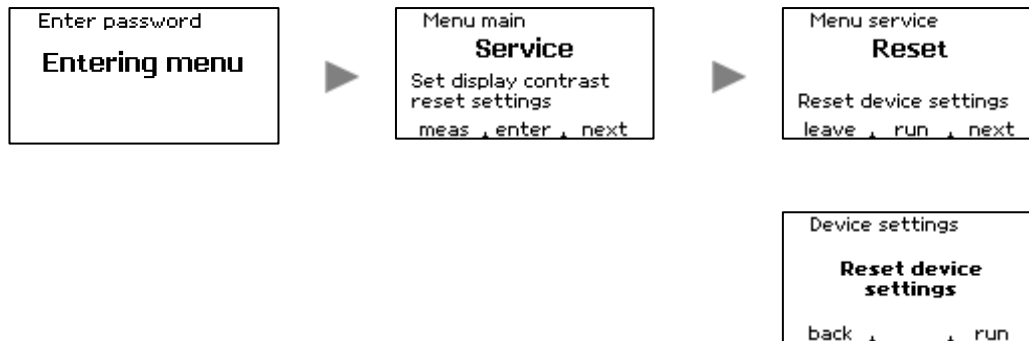

 Customized response factors that are generated via PC software SPID3 Control Center will be deleted after reset.

7.6.3 How To – Change display contrast

3. Go to the Instrument Menu, enter “Service” and “Contrast”
4. Select “change” to configure display contrast

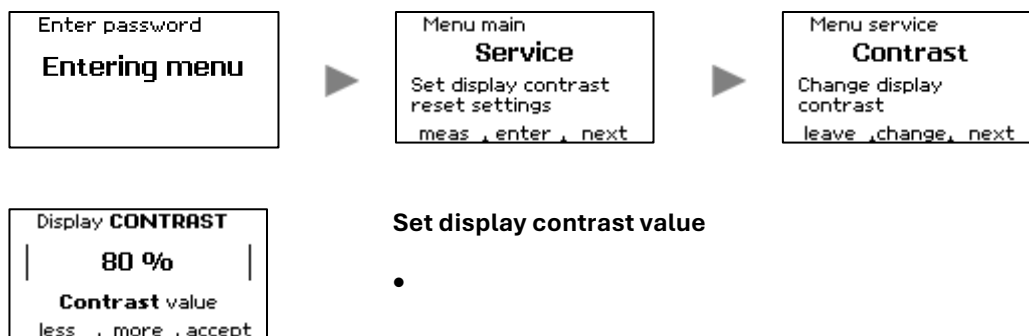

7.6.4 Diagnostic

The diagnostic allows switching the relay and set the current loop output current of the instrument for diagnostic purposes e.g. to test or measure the current loop connection.



WARNING

The instrument will switch relays and set the current loop output current to conditions which NOT equals defined instrument output states. This can lead to incorrect instrument signalling.

7.6.5 How To – Activate Diagnostic

1. Go to the Instrument Menu and enter “Diagnostic”
2. Select “next” to choose the component to diagnose

Enter password
Entering menu



Menu main
Diagnostic
Diagnostic tools
meas , enter , next

Entering diagnostic menu

Menu diagnostic
Meas PID
PID values of filter
and sample input
leave , enter , next



Meas filter input
PID curr. 2.0 pA
PID temp. 28.9 °C
PID hum. 21.8 %rH
Flow load 9.2 %
back , , sample

Test meas PID sensor values

- With gas from filter input
- With gas from sample input

Menu diagnostic
Current loop
Test
current loop
leave , enter , next



Currentloop **TEST**
4.0 mA
set to 4.0 mA
back , less , more

Test currenloop output current

- 4 mA, 12 mA, 20 mA, 24 mA, 0 mA

Menu diagnostic
Relays
Test relays
switching
leave , enter , next



Relays **TEST**
Alarm LO **energized**
Alarm HI **de-energ.**
Error **de-energ.**
back , less , more

Test states of Relays

- Relay is energised or not
- Feedback from key touch may need about 2 seconds

Menu diagnostic
Valve
Test valve
functions
leave , enter , next



Valve **TEST**
filter
back , next , select

Test Valve

- Switched to filter port
- Switched to sample port

Menu diagnostic
Touch
Test touch
functions
leave , enter , next



Touch **TEST (26 s)**
Reference 1053
Btn left 968
Btn middle 980
Btn right 983
le , mi , ri

Test touch values

- Will leave automatical after 30 seconds with no key touched

7.7 Measurement Ranges

The device supports the following measurement ranges:

	Low Range (optional)	Standard range	High range (optional)
Signal range (Isobutene equivalent)	0 ... 20 ppm	0 ... 2000 ppm	0 ... 5000 ppm
Resolution	0.001 ppm	0.01 ppm	0.1 ppm
Recommended SPAN Gas for calibration	20 ppm Isobutene	100 ppm Isobutene	2000 ppm Isobutene
Recommended ZERO Gas for calibration	Synthetic Air	Synthetic Air	Synthetic Air
Over range	24 ppm Isobutene	2400 ppm Isobutene	5500 ppm Isobutene

7.8 Resolution of Measurement Result

According to the value of the measurement result, the display value has the following digits and is rounded to:

Measurement result Isobutene	Rounded to resolution in 0 ... 2000 ppm range	Rounded to resolution in 0 ... 20 ppm range	Rounded to resolution in 0 ... 5000 ppm range
result < 5 ppm	0.01 ppm	0.001 ppm	0.1 ppm
result < 10 ppm	0.01 ppm	0.002 ppm	0.2 ppm
result < 20 ppm	0.02 ppm	0.005 ppm	0.2 ppm
result < 50 ppm	0.05 ppm	0.010 ppm	0.5 ppm
result < 120 ppm	0.1 ppm	out of range from here	0.5 ppm
result < 200 ppm	0.2 ppm		1 ppm
result < 500 ppm	0.5 ppm		2 ppm
result < 1000 ppm	1 ppm		5 ppm
result < 2500 ppm	2 ppm		10 ppm
result > 2500 ppm	out of range from here		20 ppm

7.9 Relays

The device contains two alarm relays and one error relay to control other equipment. The two alarm relays will be activated if the device detects a gas concentration that lies outside the limit values. The error relay is activated if an ERROR is detected.

Each relay has a set of change over contacts (SPDT-single pole double throw). All relays are normally energised so that are de-energised and are switched to a fail-safe condition in case of ALARM or ERROR.

During normal operation, the normally closed [NC] contacts are open. If an ALARM or ERROR is detected the relay contacts will change as follows:

- the normally closed contacts [NC] will close
- the normally open contacts [NO] will open

Relay nominal switching capacity [resistive load]:

ALARM LO	Relay	2 A / 30 V DC
ALARM HI	Relay	2 A / 30 V DC
ERROR	Relay	2 A / 30 V DC



NOTICE

Avoid peak currents higher than the 2 A maximum rating, which may be caused by inductive or capacitive loads (e.g. rotating beacons or signal horns). To operate such devices a secondary relay should be used or the peak current should be limited in another way.

7.10 Output States

State	Relay			LED	Current loop	
	Alarm LO	Alarm HI	Error	Status	4 ... 20 mA	0 ... 5/10 mA
Startup	energized	energized	energized	White <i>flash</i>	1 mA	0 mA
Menu / Maintenance	energized	energized	energized	Blue	1 mA	0 mA
Normal	energized	energized	energized	Green	4 ... 20 mA	0 ... 5/10 mA
Alarm LO	De-energized	energized	energized	Red	4 ... 20 mA	0 ... 5/10 mA
Alarm HI	De-energized	De-energized	energized	Red	4 ... 20 mA	0 ... 5/10 mA
Over range	De-energized	De-energized	energized	Red	22 mA	0 ... 5/10 mA
Under range	energized	energized	energized	Red <i>flash</i>	3 mA	0 ... 5/10 mA
Filter dirty	energized	energized	energized	Red <i>flash</i>	4 ... 20 mA	0 ... 5/10 mA
Error common	energized	energized	De-energized	Yellow <i>flash</i>	2.0 mA	0 ... 5/10 mA
Error PID lamp	energized	energized	De-energized	Yellow <i>flash</i>	2.6 mA	0 ... 5/10 mA
Error gas way	energized	energized	De-energized	Yellow <i>flash</i>	2.4 mA	0 ... 5/10 mA
Error relays	energized	energized	De-energized	Yellow <i>flash</i>	2.2 mA	0 ... 5/10 mA
Error MCU	energized	energized	De-energized	Yellow <i>flash</i>	1.8 mA	0 ... 5/10 mA
Error sensor	energized	energized	De-energized	Yellow <i>flash</i>	1.6 mA	0 ... 5/10 mA

In case of purging

- Status LED is flashing green

8 Maintenance and Service



WARNING

For safety reasons this product is supporting life and health. Equipment must be maintained and serviced by qualified personal only; otherwise the approval may be adversely affected, wrong readings could occur, and persons relying on this product for their safety could sustain serious personal injury or death.



WARNING

The device contains parts under voltage inside. Disconnect the power supply before maintenance and service.



NOTICE

The device contains electronic components, which react sensitively to electrostatic discharge (ESD). Work on or in the unit must be done only by qualified personal and in full compliance with the appropriate instructions and pertinent regulations.



NOTICE

After maintenance, it is necessary to verify that the device is functioning properly and to perform a calibration. Kinked or reversed tubing will cause a “Low gas flow” error. The gas system must not have any leaks. Blocking the sample port dust filter must trigger a “Low gas flow” Error message within approximately 10 seconds, otherwise there will be a leak.

8.1 Maintenance Intervals

The maintenance intervals must be set keeping the environmental conditions in mind (especially in high-polluted environment).

A periodic inspection of the device must be performed at least once a year. The first inspection shall take 3 month after installation.

It is strongly recommended that the maintenance intervals below be respected in order to guarantee reliable operation.

Part Number	Parts	Maintenance Interval	Comment
0002184	Dust Filter	1 times a year / or every 3 month	For use in high-polluted environment, the dust filter and filter cartridge shall be exchanged every 3 month.
0002183	Filter Cartridge	1 times a year / or every 3 month	
0002975	Front Isolation	1 times a year	The front isolation shall be exchanged no later than 1 year after continuous operation.
0002973	Lamp	every 2 years	Parts shall be exchanged no later than 2 years after continuous operation.
0003238	Pump	every 2 years	
0003237	Sensor Block	every 2 years	

8.2 Safety Screws



Safety screw for the Filter Port Unit

DO NOT LOOSE THIS SCREW !!!



Safety screw for the Sample Port Unit

DO NOT LOOSE THIS SCREW !!!



WARNING

It is not allowed to unscrew the safety screws of the Filter Port Unit and Sample Port Unit.

8.3 How To – Open the Device



Remove Locking Screw and Lid

1. Unscrew the cover locking screw.
2. Unscrew the lid of the enclosure.

Needed tools: Allen key



Remove Control unit with Display

3. Simple lift unit out with fingers.

Needed tools: none

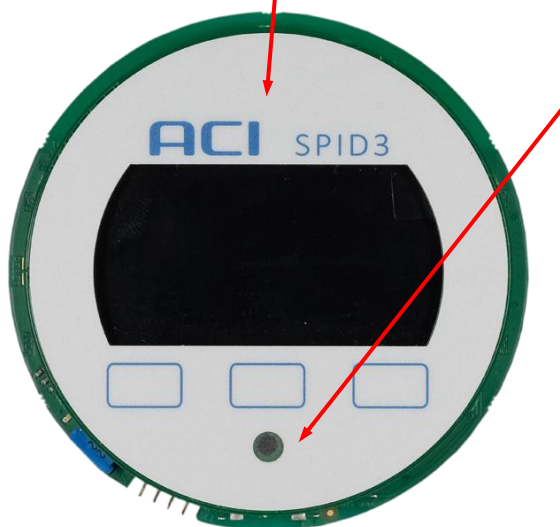

PCU-PCB become accessible



8.4 How To – Remove the PCU-PCB

Remove of PCU-PCB

1. Lift off unit at little bit with fingers.

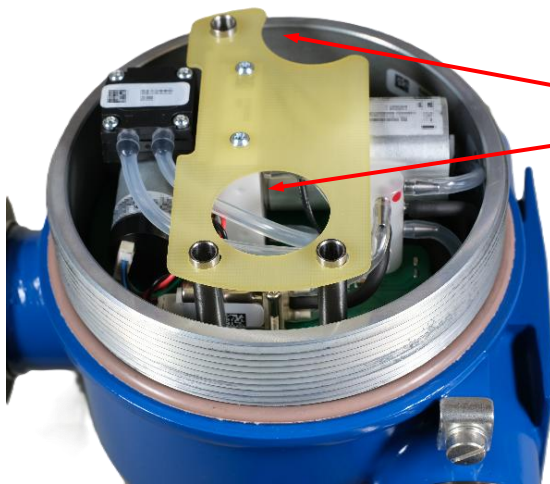

Grip fingers here

Remove of Hoses

2. Remove the flexible hoses from the tube stubs.

When reassembling, pay attention to the order and orientation of the hoses.



Complete Remove PCU-PCB

3. Remove the PCU-PCB by complete Lift-Off

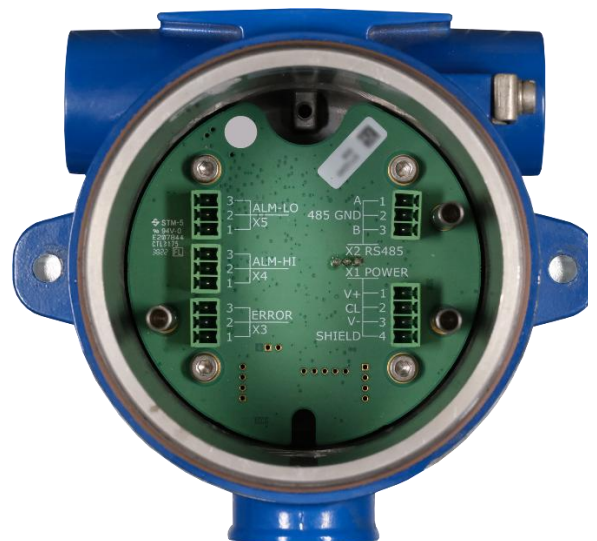
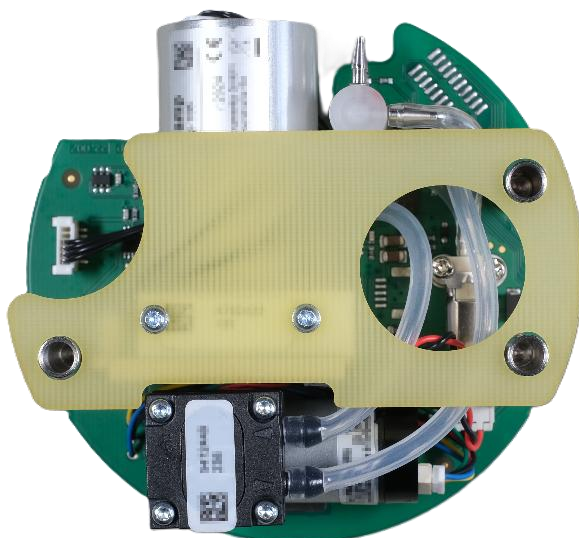

8.5 How To – Replace the PID Lamp

Remove Lamp Cable Connector

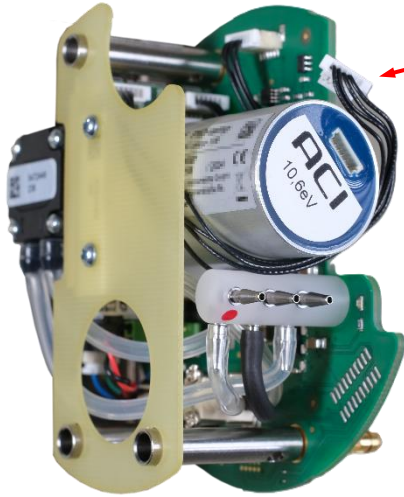

1. Gentle pull out lamp Cable Connector at lamp bottom end.
Do not unplug by pulling on the cable!

Remove PID Lamp

2. Careful turn out lamp counterclockwise.

Replace Front Isolation

3. Remove the old front isolation from the PID sensor block by using a tweezers.
4. Place the new front isolation into the PID sensor block and make sure that the curvature shows to the lamp side.

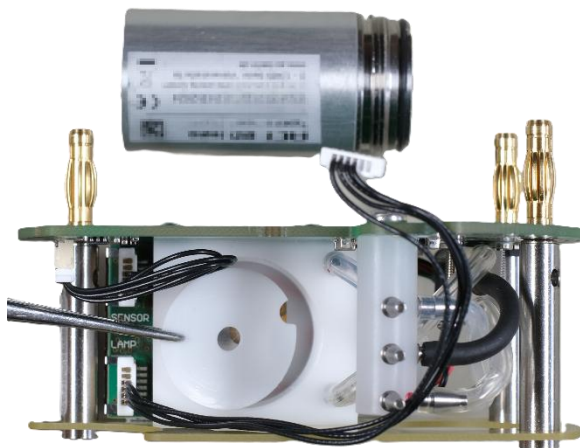

Do not bend and touch the front isolation.

The message “Filter dirty” on the display can also be caused by worn front insulation.

Note of Caution

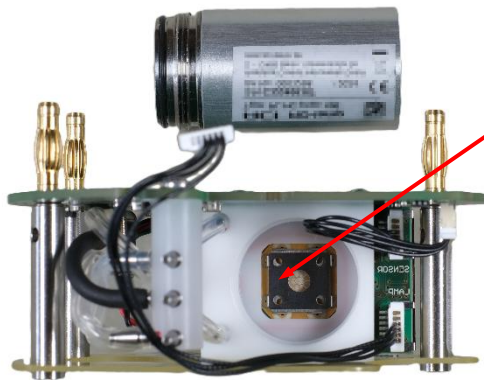

Do not touch the sensitive sensor electrodes.

Replace PID Lamp

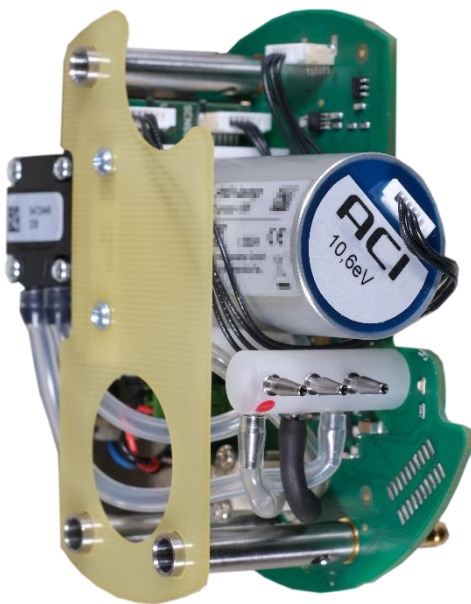

5. Check the new front isolation is inserted into the PID sensor block.
6. Screw in the bulb in a clockwise direction. This is easy at first, then a little harder until a stop is reached. Do not tighten lamp further.
7. Replace the lamp cable connector.
8. Calibrate the device after installation of a new PID lamp.

8.6 How To – Clean the PID Lamp

On normal operation over time and for most of VOCs like benzene, toluene, hexane, acetone and others when concentration does not exceed several tens of ppm, it is not necessary to clean the lamp window.

Depending on the application it can be useful to clean the lamp. If PID readings often exceed 100 ppm or other heavy compounds are measured, then it is recommended to clean the lamp window. The interval between cleaning depends on concentration level and is governed by results of checking with use of calibrating SPAN Gas.

8.6.1 Cleaning procedure:

1. Remove the PID lamp like described in chapter How To – Replace the PID Lamp.
2. For window cleaning it is recommended to use cotton buds saturated with pure methanol (analytic grade or better). Only wipe with light force onto the lamp window and rub in a circular motion. Repeat this 2-3 times.
3. After cleaning process take short brake of 1 min before the lamp will be installed into PID sensor block.
4. Switching on the device and after 15 min the calibration procedure can be started.



CAUTION

Follow common safety instruction for using methanol



Do not touch the lamp window during installation.
Calibrate the device after cleaning or replacing the lamp.

8.6.2 Hose routing inside the unit:

1. Route the hoses from the filter cartridge connection behind the connecting columns.
2. The hoses must not be twisted together.
3. Please check that the hoses are connected correctly in the right order.
4. When inserting the PCU PCB, ensure that the hoses are not trapped between the lamp end and the housing.



CAUTION

Trapped hoses can cause the device to malfunction. No gas detection, error code 'Low gas flow'.

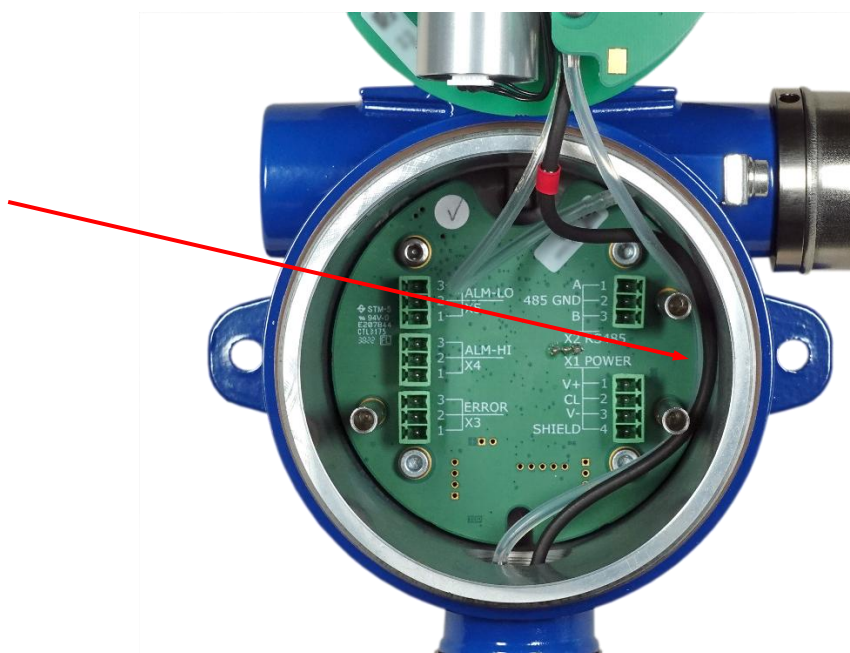

8.7 How To – Replace the Filter Port – Filter Cartridge

The filter cartridge must be replaced, if the message “Filter dirty” will be shown on display.



Remove Filter Port – Filter Cartridge

1. Unscrew the old filter cartridge counter-clockwise.



Replace Filter Port – Filter Cartridge

2. Check that the filter port – seal is fitted and not damaged.
3. Check that the filter cartridge – seal is not broken.
4. Screw the filter cartridge into the filter port unit.
Only light force is required!!!
5. Open the filter cartridge after installation by using the opener.

For detailed information, see chapter 5.3



Calibrate the device after installation of a new filter cartridge.

8.8 How To – Replace the Sample Port – Dust Filter

The Dust Filter must be replaced, if the sample port flow load indicator (chapter display overview) is almost full. If the filter is particularly dirty, a 'Low Flow' error may also occur, in which case the device is without function.

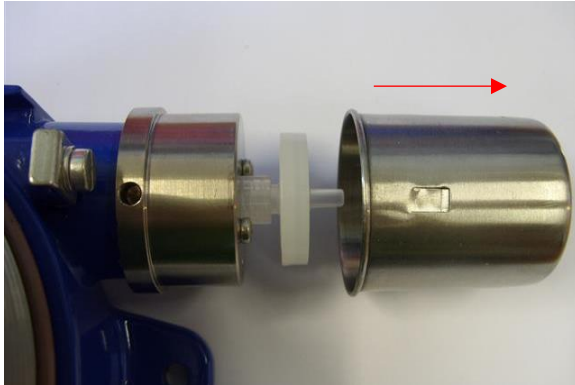

Remove Sample Port – Protection Cap

1. Remove the protection cap by pulling it sideward.



Replace Sample Port – Dust Filter

1. Unscrew the dust filter counter-clockwise.
2. Replace the dust filter by a new one.
3. Replace the protection cap.



Replace the filter in good time (flow load indicator in display).

Calibrate the device after installation of a new dust filter.

8.9 Configurion jumper and service communication

Remove Locking Screw and Lid

1. Unscrew the cover locking screw.
2. Unscrew the lid of the enclosure.

Needed tools: Allen key



Positions of service communication plug and config jumpers at Control unit with Display



Detail to Control unit with Display

1. Attach USB service communication cable to blue connector
2. Configuration jumper positioning

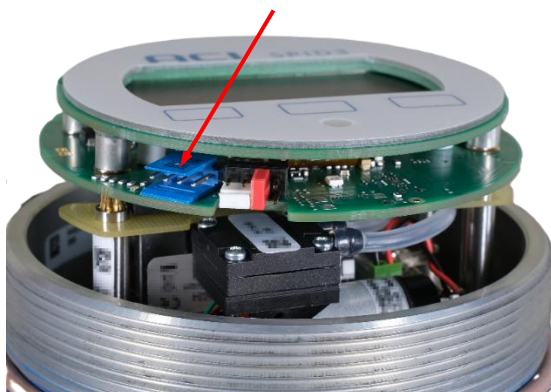

8.10 Default configuration jumper attachment



Detail to configuration jumper

1. Jumper for Firmwareupdate of MCU is disabled by attaching it to the 2 lower left pins
2. Jumper (second from right) for availability of remote access is attached for enable

8.11 How To – Connect to configure and update device with service communication

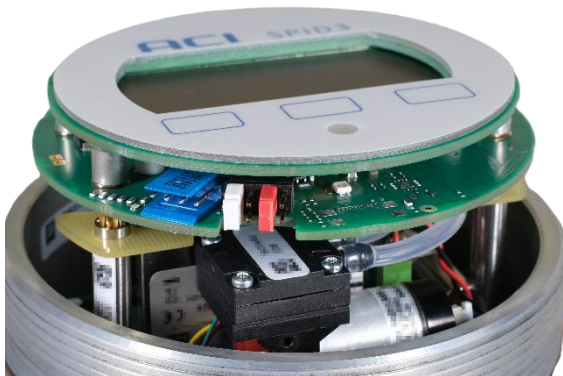

Detail to Firmwareupdate jumper

1. Attaching jumper (far left) for Firmwareupdate of MCU will be prompted during Device update

9 Technical Data

Detector principle	VUV- Photoionization with 10.6 eV hollow cathode lamp with Ceramic Discharge Channel (optional 11,8 eV lamp)
Detection ranges	R0 – 0 ... 2 000 ppm Isobutene * R1 – 0 ... 20 ppm Isobutene * R2 – 0 ... 5000 ppm Isobutene *
Display range	0 ... 20 000 ppm, depending on response factor of detected substance
Lower detection limit	R0 – typisch 0,05 ppm Isobutene * R1 – typisch 0,005 ppm Isobutene * R2 – typisch 0,5 ppm Isobutene *
Display resolution	Dynamic
Response time	T90 < 10 s *
Signal integrity	Up to 100 ppm typical > 98 % * Up to 2 000 ppm typical > 95 % *
Influence of humidity	Humidity and temperature compensation at -10 ... 55 °C and 0 ... 90 % rH residual effect less than < 10 %
Operating condition	-10 ... 55 °C 0 ... 95 % rH, non-condensing
Storage conditions	-20 ... 60 °C 0 ... 95 % rH, non-condensing
Gas sampling	Integrated diaphragm pump (about 250 ml/min) with flow detection Sample inlet with dust and water protection cap
PID lamp life time	10,6 eV: Min. 8 000 hours, typical more than 15 000 hours 11,8 eV: 4 months from delivery
Alarms	2 adjustable alarm levels
Power supply	10 ... 28 VDC, max. 4 W, recommended 24 VDC
Signalisation	1 x LED (multicolor) for status and alarms
Relays	3 x SPDT 30 VDC / 2 A (surge current), 2 x for alarms, 1 x for error
Analog output	Current loop, 4 ... 20 mA, 0 ... 5 mA or 0 ... 10 mA (type-dependent)
Digital interfaces	RS485 (MODBUS) (type-dependent) HART (type-dependent)
Calibration	Automatically two point calibration Zero gas via activated char coal filter, span gas via sample inlet
Response factors	Selectable built-in response factors, changeable via remote service program
User interface	Graphical monochrome OLED display, touch keys
Dimension, weight	200 mm x 370 mm x 133 mm (L x W x H), about 2200 g
Ingress Protection	IP64

- * The indicated values were obtained under standardized conditions with 10.6 eV lamp.
Test gas was isobutene in synthetic air.

10 Approvals

10.1 Marking, Certificates and Approvals According to the Directive 2014/34/EU (ATEX)

Product: **Stationary Photoionization Detector SPID3-***

Manufacturer: ACI Analytical Control Instruments GmbH
Volmerstraße 9A
D-12489 Berlin
Germany

Type of protection: EN IEC 60079-0:2018, EN 60079-1:2014

Marking:  II 2G Ex db IIC T6 Gb -40 °C ≤ Ta ≤ +60 °C

Type key:

SPID3 - R* - D* - L* - S* - A* - C*

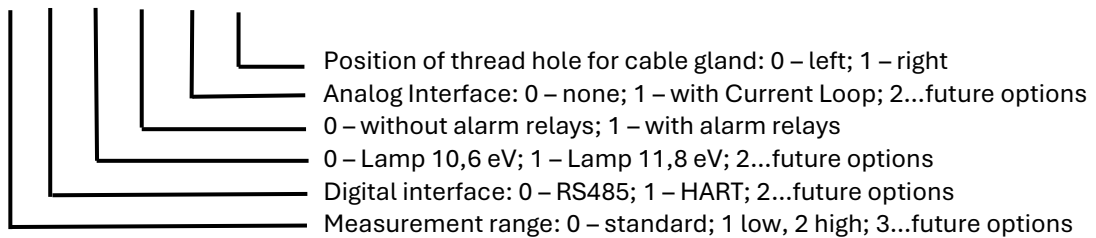

Rated voltage: 10 VDC ÷ 28 VDC

Maximum power dissipation: 4 W

EC-Type Examination Certificate: FTZÚ 15 ATEX 0110X

Quality Assurance Notification: 1026

Year of Manufacture: see Label

S/N: see Label

Stationary Photoionization Detector

Type : SPID3-R0-D0-L0-S0-A0-C0

S/N : 579XXXXXXXX / 2023

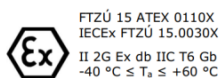

10 VDC ÷ 28 VDC
≤ 4 W
cable gland for M20 x 1,5



Analytical Control Instruments GmbH
D - 12489 Berlin, Volmerstraße 9a
<http://www.aci-berlin.com>



10.1.1 Special Conditions for Safe Use

- Ambient temperature range: $-40\text{ °C} \leq T_a \leq +60\text{ °C}$
- Verified values of the maximum gaps and minimum constructional length of flameproof joints of this enclosure are different from relevant minimum and maximum values mentioned in standard. To obtain information about joints dimension it is necessary to contact the manufacturer.
- Do not open the instrument when energised.
- Intensive electrostatic charging processes have to be prevented.
- Maintenance or repairment according to the type of protection "d" is only allowed by the manufacturer.
- IP64 – vertical, filter unit down

Cable gland

- The housing of the detector has to be equipped with flameproof cable gland Ex d IIC certified according to ATEX and or IECEx.
- M20 x 1,5; Torque 8 – 12 Nm

10.1.2 EMC Conformance according to the Directive 2014/30/EU

EN 50270:2015 Type 2,

10.2 Marking and Certificates according to IECEx

Product: **Stationary Photoionization Detector SPID3-***

Manufacturer: ACI Analytical Control Instruments GmbH
Volmerstraße 9A
D-12489 Berlin
Germany

Type of protection: EN IEC 60079-0:2018, EN 60079-1:2014

Marking:  Ex db IIC T6 Gb -40 °C ≤ Ta ≤ +60 °C

Type key:

SPID3 - R* - D* - L* - S* - A* - C*

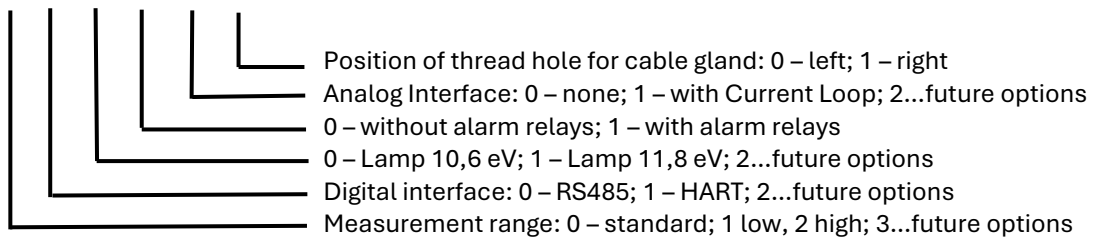

Rated voltage: 10 VDC ÷ 28 VDC

Maximum power dissipation: 4 W

IEC-Type Examination Certificate: IECEx FTZÚ 15.0030X

Quality Assurance Notification: 1026

Year of Manufacture: see Label

S/N: see Label

Stationary Photoionization Detector

Type : SPID3-R0-D0-L0-S0-A0-C0

S/N : **579XXXXXXXX** / 2023

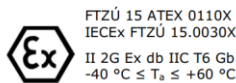

10 VDC ÷ 28 VDC
≤ 4 W
cable gland for M20 x 1,5

CE 1026

ACI Analytical Control Instruments GmbH

Analytical Control Instruments GmbH
D - 12489 Berlin, Volmerstraße 9a
<http://www.aci-berlin.com>



10.2.1 Special Conditions for Safe Use

- Ambient temperature range: $-40\text{ °C} \leq T_a \leq +60\text{ °C}$
- Verified values of the maximum gaps and minimum constructional length of flameproof joints of this enclosure are different from relevant minimum and maximum values mentioned in standard. To obtain information about joints dimension it is necessary to contact the manufacturer.
- Do not open the instrument when energised.
- Intensive electrostatic charging processes have to be prevented.
- Maintenance or repairment according to the type of protection "d" is only allowed by the manufacturer
- IP64 – vertical, filter unit down

Cable gland

- The housing of the detector has to be equipped with flameproof cable gland Ex d IIC certified according to ATEX and/or IECEx.
- M20 x 1,5; Torque 8 – 12 Nm

10.2.2 EMC Conformance according to the Directive 2014/30/EU

EN 50270:2015 Type 2,

11 Appendix

11.1 Error Messages

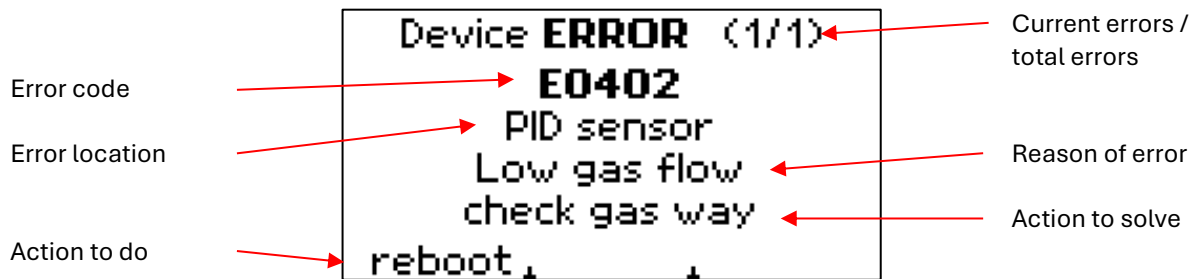

```
Device ERROR (1/1)
E0402
PID sensor
Low gas flow
check gas way
reboot
```

If an error is detected, the error message, followed by a short description, will be displayed. In this case, the normal operation of the device will not respond to gas and the current loop output will be the ERROR value.

Code	Location	Cause	Troubleshooting
E0401	PID sensor	Intern comm check connections	Check that the cable between PID sensor and PCU-PCB is well connected
E0402	PID sensor	Low gas flow check gas way	Check the sample port inlet dust filter Check the gas lines for kinks and pump working Check for reversed connected hoses
E0406	PID sensor	PID lamp not ignited	Replace PID lamp
E0407	PID sensor	PID lamp malfunction	Check that the PID lamp connector is well connected to the PID sensor
E0102 E0103 E0104	IO control unit	Alarm LO relay Alarm HI relay Error relay does not switch	Restart the device.
E0105	IO control unit	Current loop IC does not work	Restart the device.
E0202	PID control unit	Valve function does not switch	Check that the valve connector is well connected.
E0610	SPID3 device	Filter input low flow	Check the gas lines for kinks and pump working

If the error code is still shown after a restart and troubleshooting, the device could be defective.

For additional support, please contact the manufacturer.

11.2 Mechanical Drawing

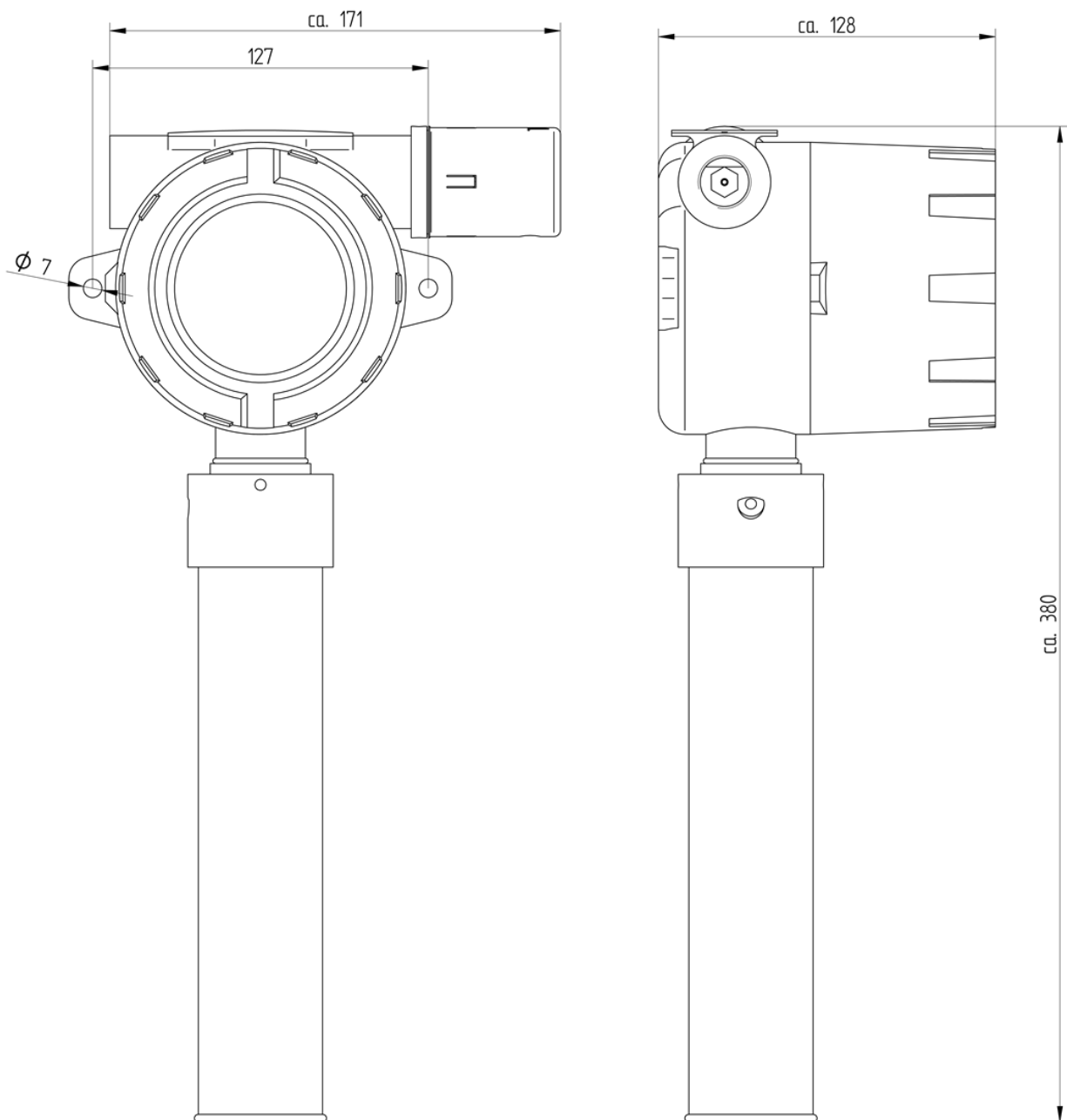

Dimensions shown in millimeters.

12 Contact Information

ACI Analytical Control Instruments GmbH

Volmerstraße 9A

D-12489 Berlin

Germany

Tel: +49 30 7543 97710

Fax: +49 30 7543 97711

www.aci-berlin.de

13 Ordering Information

Available options:

- I. **R0** Detection Range (Standard Range 0 ... 2000ppm)
 - R1 Detection Range (Low Range 0 ... 20ppm)
 - R2 Detection Range (High Range 0 ... 5 000ppm)
- II. **D0** Digital Interface (RS485 with MODBUS only)
 - D1 Digital Interface (HARTBUS only)
 - D2 No Digital Interface
 - D3 Future Option
- III. **L0** Lamp (10.6 eV)
 - L1 Lamp (11.8 eV)
- IV. **S0** Alarm Relays (Without Relays)
 - S1 Alarm Relays (With Relays)
- V. **A0** No Current Loop
 - A1 With Current Loop
- VI. **C0** Cable Gland (Left)
 - C1 Cable Gland (Right)

The following variants are available as standard.

	I.	-	II.	-	III.	-	IV.	-	V	-	VI	ACI Part No.	
SPID3	-	R0	-	D2	-	L0	-	S0	-	A1	-	C0	0003327
SPID3	-	R0	-	D0	-	L0	-	S1	-	A1	-	C0	0003239
SPID3	-	R0	-	D1	-	L0	-	S1	-	A1	-	C0	0003317
SPID3	-	R1	-	D0	-	L0	-	S1	-	A1	-	C0	0003323
SPID3	-	R1	-	D1	-	L0	-	S1	-	A1	-	C0	0003324
SPID3	-	R2	-	D0	-	L0	-	S1	-	A1	-	C0	0003326
SPID3	-	R2		D1		L0		S1		A1		C0	0003328

Other variants are available on request.

14 Scope of Delivery

Part Number	Description	
SPID3-R0-D0-L0-S1-A1-C0	SPID3 complete device with: <ul style="list-style-type: none"> • 1 x 10.6eV VUV lamp • 1 x Filter Cartridge • 1 x Dust Filter • 1 x Screw drivers for maintenance and service • Terminal connectors 1 x Power, 1 x RS485 (MODBUS), 3 x Relay • 1 x User manual • 1 x Declaration of conformity • 1 x Certificate of inspection 	Scope of delivery varies according the ordered type

15 Spare Parts

Part Number		
0002183	Filter Cartridge	
0002184	Dust Filter	
0002881	long life dust filter element	
0002452	Sample Port – Protection Cap	
0002975	Front Isolation Pack	
0003238	pump kit	

Part Number		
0002973	SPID3 – Lamp Kit 10.6 eV	
0003343	SPID3 – Lamp Kit 11.8 eV	
0003237	Std Sensorblock Kit	
0003321	Low Sensorblock Kit	
0003331	High Sensorblock Kit	
0003380	PID Control Unit without sensor and lamp, please order separately	

0003381	Tube maintenance set <ul style="list-style-type: none">• 25 cm Viton tube• 25 cm Silicone tube• 25 cm inert tube	
---------	---	---

16 Accessories

Part Number		
0002873	long life dust filter	
0003332	Calibration Kit <ul style="list-style-type: none"> • T-piece with Tubes • Flow Controller with pressure indicator 	
0003319	USB service communication kit	
0003354	Weather protection	
0003374	Mounting bracket	

ACI Analytical Control Instruments GmbH
Volmerstraße 9A
D-12489 Berlin
Germany

Tel: +49 30 7543 9771 0
Fax: +49 30 7543 9771 1
www.aci-berlin.de

© ACI Analytical Control Instruments GmbH. All rights reserved.